

HCB

High-Speed Hand Chain Hoist

2.5 to 50 metric tonne, runs 7 times faster when unloaded

Save time and increase efficiency lifting heavy loads with Kito's High-Speed Hand Chain Hoist. Using the world's first built-in high/low clutch technology, this heavy duty hoist operates to standard specifications when loaded, but runs up to seven times faster when unloaded.



FEATURES

- » 7:1 ratio saves time when repositioning an unloaded hook
- » Automatic change from high to low speed based on load
- » Compact design for lightweight portability
- » Safe, reliable mechanical brake activates instantly, holds the load securely
- » Abrasion resistant load chain is made from heat-treated alloy steel for high, uniform strength
- » Forged carbon steel hook design will not fracture under excessive load
- » Sealed gears and brake protected against damage from dust and water
- » Open load sheave allows easy inspection and cleaning without dismantling the unit
- » Maintenance-free sealed bearings increase reliability and reduce the pull required to lift loads
- » Heat treated load bearing parts are hardened for long, trouble-free life
- » Double-pawl spring system for increased safety and reliability
- » Available in 2.5 through 50 metric tonne capacities

STANDARDS

- » ASME B30.16 Safety Standard
- » ASME HST-2 Performance Standard
- » 125% of rated capacity test load
- » Grade 100 Chain

OPTIONS

- » Chain bag to keep chain clean and out of the way
- » Corrosion resistant chain for tough environments
- » Custom lift lengths to suit your requirements
- » Plain or Geared trolley mount for improved load control

HOW IT WORKS



Watch this short informative video to see how the HCB can improve your workplace efficiency up to 24%

VISIT: WWW.KITO.CA/HCB

NEW
TECHNOLOGY



QUICK CLUTCH
MECHANISM

KITO

WWW.KITO.CA | 1 888 322 KITO (5486)

All specifications, dimensions and drawings are available at www.kito.ca, or call our Customer Service staff for friendly and expert advice on models and options.

PRINTED IN CANADA | HCB - ENG - 12

HCB 2.5 to 50 metric tonne

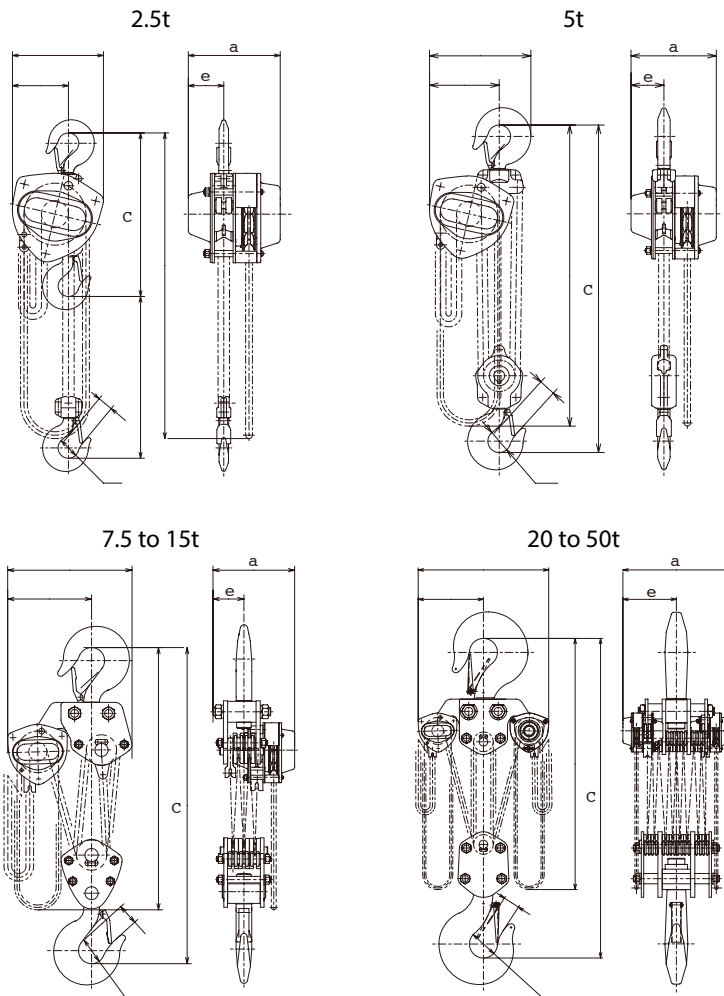

SPECIFICATIONS

Capacity (tonne)	Model	Chain Pulled to Lift Load One Meter (m)		Load Chain Falls	Hand Chain Falls	Hand Pull to Lift Full Load (kg)	Load to Engage High-Speed (tonne)	Dimensions			Ship Weight (lbs)	Weight per 5 ft of Lift (lbs)
		Unloaded	Loaded					(a) (mm)	(e) (mm)	(C) Headroom (in)		
2½	HCB025	14	99	1	2	33	0.25 or less	237	91	16.5	75	9
5	HCB050	28	198	2	2	34	0.5 or less	237	91	23.6	106	15
7½	HCB075	42	297	3	2	35	0.7 or less	237	91	30.5	154	21
10	HCB100	56	396	4	2	36	0.9 or less	237	111	30	198	27
15	HCB150	85	594	6	2	37	1.3 or less	313	119	40.25	357	38
20	HCB200	56x2	396x2	8	4	36x2	1.8 or less	464	232	46.5	549	53
30	HCB300	71x2	495x2	10	4	48x2	2.2 or less	494	247	51.2	714	65
40	HCB400	99x2	693x2	14	4	49x2	2.9 or less	592	296	58.3	1089	88
50	HCB500	113x2	792x2	16	4	54x2	3.2 or less	634	317	61.5	1442	100

¹ Load must be greater than the engagement point for the automatic clutch to perform in low speed.

² All dimensions other than the ones listed above are the same as the standard M3CB Series Hand Chain Hoist.