

SER

Series Electric Chain Hoists

**1/4 to 3 metric tonne capacity, single phase (115/220V)
proven reliability**



Harrington's SER electric chain hoists are built for extreme duty applications that require single phase power. A hoist with a 60 minute, H4 duty rated motor is revolutionary and unmatched in a single phase offering. Maintenance friendly features include a unique chain guide, hinged control panel, sealed housing and durable load sheave.

FEATURES

- » 60 minute, H4 rated, fan cooled motor for the most demanding applications
- » Ability to accommodate long lifts
- » Advanced fail-safe pull rotor brake is self-adjusting and virtually maintenance free
- » Compact, low headroom design for work in tight spaces
- » Standard upper limit switch protects the hoist from overlifting
- » Spur gears immersed in oil bath ensure quiet, smooth operation and long life
- » Unique chain guide design for smooth chain travel
- » Friction clutch protects the hoist against over travel and overload damage
- » 360° swivel bottom hook with built-in bearing, for easy positioning
- » Weathertight construction resists dust and water
- » Tested to 125% of rated capacity

Duty Ratings	Single Speed
ASME Class	H4
Max. Starts / hr	360
%ED	60
Short Time Rating	60 min

STANDARDS

- » CSA Electrical Approval
- » ASME B30.16 Safety Standard
- » ASME HST-1 Performance Standard
- » Grade 80, Nickel-plated Load Chain
- » IP55 Environmental Protection

OPTIONS

- » Chain bag to keep chain clean and out of the way
- » Custom lift lengths to suit your requirements
- » Plain or Geared trolley mount for improved load control

115
VOLTS

220
VOLTS

SER 1/4 to 3 metric tonne capacity

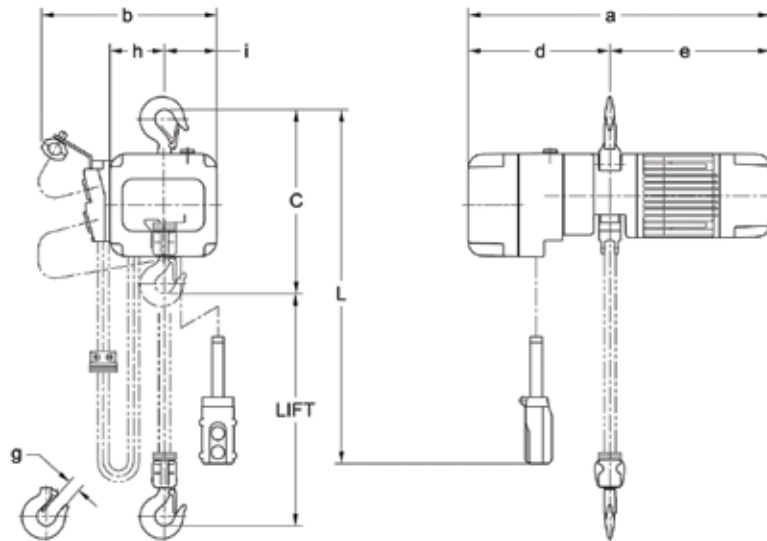

DIMENSIONS (in)

Capacity (tonne)	Model	C	a	b	d	e	g	h	i
¼	SER003S	13.8	22.2	13.0	10.4	11.9	0.9	4.0	3.9
½	SER005L	14.0	22.2	13.0	10.4	11.9	0.9	4.0	3.9
½	SER005S	14.6	23.2	13.8	10.6	12.6	0.9	4.7	4.1
1	SER010L	16.1	23.2	13.8	10.6	12.6	1.2	4.7	4.1
1	SER010S	17.3	26.9	16.5	12.4	14.4	1.2	6.1	5.2
2	SER020L	22.6	26.9	16.5	12.4	14.4	1.5	6.1	5.2
3	SER030C	29.5	26.9	16.5	12.4	14.4	1.7	8.2	3.0

SPECIFICATIONS

Capacity (tonne)	Model	Lift Speed (ft/min)	Hoist Motor H.P.	Rated Current (amps)		Headroom (in)			Load Chain Code	Load Chain Falls	Ship Weight 10' Lift (lbs)	Weight per Additional 5 ft of Lift (lbs)
				@ 115V	@ 230V	Hook Mount	Plain Trolley	Geared Trolley				
¼	SER003S	14	0.34	7.7	3.9	13.8	15.4	16.1	KER050	1	82	1.85
½	SER005L	7	0.34	7.7	3.9	14.0	15.4	16.1	KER063	1	84	2.85
½	SER005S	15	0.6	16.9	8.5	14.6	16.1	16.9	KER063	1	104	2.85
1	SER010L	7	0.6	16.9	8.5	16.1	18.1	18.1	KER080	1	110	4.65
1	SER010S	14	1.2	23.9	12	17.3	19.5	19.5	KER080	1	159	4.65
2	SER020L	7	1.2	23.9	12	22.6	24.6	24.6	KER100	1	174	7.5
3	SER030C	3.5	1.2	23.9	12	29.5	29.3	29.3	KER100	2	207	15.5