

# ER2CL SERIES

## Single-handed operation. Three-phase power.

Ergonomically designed, this 3-phase cylinder control ER2CL Series provides all that you need for a safe and easy operation. It features a Guardian Smart Brake technology - an electrical fail-safe design and an in-line grip for one-handed operation allowing the user's free hand to position the load easily. Wherever the location, the sealed body allows this dual speed hoist to withstand indoor or outdoor hazardous environments. The ER2CL is engineered to deliver comfort, safety and peak performance.

### Smart Brake Technology

The ER2CL's Guardian Smart Brake has an electrical fail-safe design that uses DC current to control brake activation. The fast activation drastically reduces wear on the brake discs, preserving the correct brake gap. The result is a maintenance-free braking system with a 10-year/2,000,000 activation cycle warranty.

### EXTREME-DUTY TEFC MOTOR

Equipped with thermal overload protection and cooling fins on all four sides of the motor housing, the ER2CL's totally enclosed fan-cooled motor (TEFC) efficiently dissipates heat, allowing for industry-leading duty ratings.

### Ergonomic In-Line Hand Grip Control

The ergonomic, in-line hand grip control allows for single-handed operation, which gives the operator a free hand to safely guide and position the load.

### Count Hour Meter

The count hour meter records the hoist's starts and run time. This gives maintenance personnel an accurate record of the hoist's operating profile, letting them customize its maintenance schedule to optimize the hoist's life and improve workplace safety.



# ER2CL SERIES

## CAPACITY

- Single Speed: 1/8 to 1/4 metric tonnes
- Dual Speed: 1/8 to 1/4 metric tonnes

## STANDARDS

- CSA approved
- ASME B30.16
- ASME H4
- ISO M5
- FEM 2m or 1Am
- IP55 dust-tight and watertight
- Slip clutch to protect the hoist against over travel and overload damage

## OPTIONS

- Plastic, canvas or steel chain containers
- Long lift chain container
- Lift lengths can be customized to suit requirements
- Plain, geared, or motorized trolley mount

## BODY

- Die cast aluminum frame
- Completely sealed body for environmental protection
- Low headroom

## GEARS

- Precision, induction-heated, durable alloy steel helical gears submersed in an oil bath

## LOAD CHAIN

- Ultra-strong high-performance nickel-plated load chain, with unique short link pitch for greater resistance to fatigue and wear
- Grade 80, certified to DIN standards

## CHAIN GUIDE

- Long-lasting, heavy-duty cast iron construction, easily replaced without disassembling hoist

## HOOKS

- Forged carbon steel opens gradually without fracturing under excessive loads. Bottom hook swivels 360 degrees
- Self-closing top and bottom hooks with heavy-duty hook latch

## ERGONOMIC CYLINDER CONTROL

- Ergonomic Cylinder Control Ideal for repetitive tasks- available in Adjustable 2-speed (220/440 volt) Dual Speed (575 volt)

## CONTROLS

- Controls located on a central electrical panel
- Control Voltage: 110 volts
- Adjustable, dual-speed, under-the-cover VFD (220 and 440 volt dual speed models)
- Simple to operate plug-in connectors

## BEARINGS

- High-quality, anti-friction ball and roller design

## BRAKE

- DC current electromagnetic brake stays engaged until powered (Industry leading 10 year warranty)
- Minimum brake torque of 200% at full load

## MOTOR

- Three phase
- Standard Voltage: 220/440/575 volts
- 60 hertz
- Class B
- Extreme duty, totally enclosed, fan-cooled (TEFC) squirrel cage
- Motor fin, fan blade and fan cover design for optimum air flow

## OVERLOAD PROTECTION

- Friction clutch located in the gearbox between motor and load gear prevents damage to hoist in the event of excessive overloading

## OVERTRAVEL PROTECTION

- Limit switch disables controls when load block reaches upper or lower travel limit

## OPERATING CONDITIONS

- Recommended for -20° to +40° C and humidity of 85% or lower

# ER2CL | DUAL SPEED -575V HOOK MOUNT

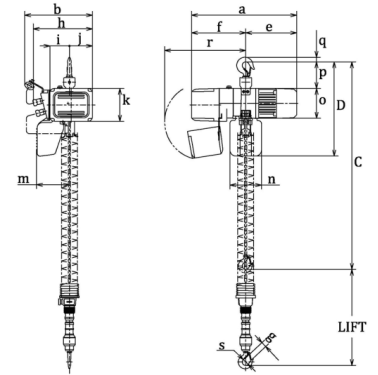

## DIMENSIONS

Capacity (tonne)	Model	a	b	C(Inches)	D	e	f	g	h	i	j	k	L	m	n	o	p	q	r	s
1/8	ER2C001HD	478	321	40	430	259	219	27	280	99	93	167	6	167	160	152	80	23.5	390	35.5
1/4	ER2C003SD	478	321	40	430	259	219	27	280	99	93	167	6	167	160	152	80	23.5	390	35.5

## SPECIFICATIONS

Capacity (tonne)	Model	Standard Lift (ft)	Hoist Lifting Speed (ft/min)	Hoist Motor H.P.	Headroom (in)	Rated Current (amps) 575V	Load Chain Code	Load Chain Falls	Ship Weight (lbs)	Weight per Additional 5ft of Lift (lbs)
1/8	ER2C001HD	6	55/11	0.75	40	1.4/0.9	KER2043	1	68	1
1/4	ER2C003SD	6	28/7	0.75	40	1.4/0.9	KER2043	1	68	1

# ER2CL

# ADJUSTABLE 2 SPEED (VFD) - 220V-440V HOOK MOUNT

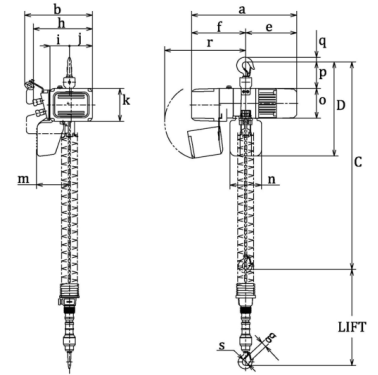

## DIMENSIONS

Capacity (tonne)	Model	a	b	C(Inches)	D	e	f	g	h	i	j	k	L	m	n	o	p	q	r	s
1/8	ER2C001IH	535	345	42	490	259	276	27	300	99	117	167	6	167	160	152	136	23.5	413	35.5
1/4	ER2C003IS	535	345	42	490	259	276	27	300	99	117	167	6	167	160	152	136	23.5	413	35.5

## SPECIFICATIONS

Capacity (tonne)	Model	Standard Lift (ft)	Hoist Lifting	Hoist Motor H.P.	Headroom (in)	Rated Current (amps) 220V	Rated Current (amps) 440V	Load Chain Code	Load Chain Falls	Ship Weight (lbs)	Weight per Additional 5ft of Lift (lbs)
1/8	ER2C001IH	6	55/9	0.75	42	3.6	1.8	KER2043	1	68	1
1/4	ER2C003IS	6	36/6	0.75	42	3.6	1.8	KER2043	1	68	1

# ER2CL

# SINGLE SPEED -575V HOOK MOUNT

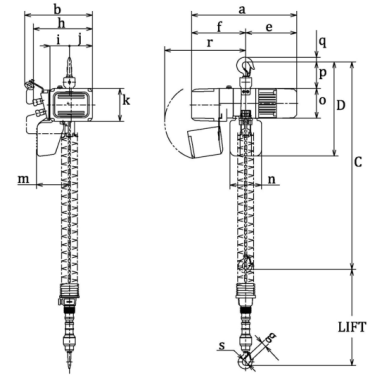

## DIMENSIONS

Capacity (tonne)	Model	a	b	C(Inches)	D	e	f	g	h	i	j	k	L	m	n	o	p	q	r	s
1/8	ER2C001HD	478	321	42	490	259	219	27	280	99	93	167	6	167	160	152	80	23.5	390	35.5
1/4	ER2C003SD	478	321	42	490	259	219	27	280	99	93	167	6	167	160	152	80	23.5	390	35.5

## SPECIFICATIONS

Capacity (tonne)	Model	Standard Lift (ft)	Hoist Lifting Speed (ft/min)	Hoist Motor H.P.	Headroom (in)	Rated Current (amps) 575V	Load Chain Code	Load Chain Falls	Ship Weight (lbs)	Weight per Additional 5ft of Lift (lbs)
1/8	ER2C001HD	6	55	0.75	42	1.4	KER2043	1	68	1
1/4	ER2C003SD	6	35	0.75	42	1.4	KER2043	1	68	1