

TNER SERIES

Trusted when the show must go on.

While other show motors are out of commission for brake service or regular repair, Harrington's TNER theatre hoist by Kito is ready when duty calls. That's because the TNER is built using the latest technology powered by innovative design and manufacturing processes, and backed up by outstanding customer support when you need it.

Self-Adjusting Pull-Rotor Motor Brake

This is the world's most reliable theatrical hoist brake — it even comes with a five-year warranty. Its simple design has no brake coil to fail or discs to replace, which keeps this hoist working longer with less maintenance.

Unique Chain Guide and Quiet Load Sheave

The guide's durable, heavy cast iron construction gives it improved wear as the chain is quietly, smoothly guided where it needs to go. There's less vibration and truer vertical lift.

Ergonomic, Easy Lift Handles

Two convenient handles give you a comfortable and confident grip every time you pack or unpack your motors.

Plug and Play Voltage Changer

You can change on the fly between 220/440V, which saves you valuable time during setup and integration. It's as simple as plug and play.

Non-drip, Grease-Packed Gearbox

For demanding theatrical applications, this maintenance free feature is a welcome touch.

Standard Overload Protection

Carbon friction material gives the TNER consistent performance even in a wide range of temperatures. The friction clutch on the TNER also protects the hoist from damage and prevents overwinding.



TNER SERIES

CAPACITY

- 1/2 – 2 tonnes

STANDARDS

- Standard lifts at 10 or 60 feet.
- Hoist must be purchased with chain container
- 1 year warranty (from defects in material and workmanship)

RATINGS/CLASSIFICATIONS

- Complies with German regulation BGV-D8
- Meets CE declaration
- ASME H3
- JS/ISO M3
- FEM 1Bm
- Hoist — IP55
- Optional pendant — NEMA 4X,

OPTIONS

- Black pendant (Pickle)
- Pendant and power supply cord (longer lengths available)
- 7 pin socapex connector
- Flight/road case for easy transportation and hoist storage
- Black load chain for low visibility
- Bullard® hooks

BODY

- Sleek rounded body with rugged aluminum housing and no sharp edges
- Built-in, flexible handles for effortless packing and unpacking
- Body size is designed to fit standard road cases.

GEARS

- Grease-Packed Gearbox for demanding theatrical applications.
- Maintenance free. No oil changes required.

LOAD CHAIN

- Nickel-plated load chain meets DIN and EN 818-7 standards.
- Optional black chain available for low visibility
- Reversible black canvas chain container needed to meet BGV-D8 regulations with two secure attachment points.
- Standard Lift 60' (other lengths available)

CHAIN GUIDE

- Extremely durable, heavy-duty cast iron construction, with rounded outer edge for chain to spill easily over and into the chain bag.
- Easily replaced without disassembling hoist

HOOKS

- Forged carbon steel opens gradually without fracturing under excessive loads.
- Both top and bottom hooks swivel 360 degrees
- Self-closing top and bottom hooks with heavy-duty hook latch
- Ball bearings for smooth rotation.

CONTROLS

- Standard offering - double pigtail configuration for use with own hoist connectors
- Single pigtail configuration - 7 pin conductors to supply hoist with power and to control hoist operation
- 7-pin socapex - for use with a multi-hoist controller
- Pickle (pendant) with power cord pigtail - similar to the standard used for industrial hoists

BRAKE

- 5 year warranty
- Pull-rotor motor brake- the world's most reliable theatrical hoist brake.
- Simple design, no brake coil to fail or brake disc to replace.

MOTOR

- ½ and 1 tonne— 16 fpm; 2 tonne—8 fpm.
- H3 classification with 30 minute duty rated motor
- Standard voltage: 220/440
- Three phase, 60 hertz
- Control voltage - 110V

OVERLOAD PROTECTION

- Friction clutch located in the gearbox between motor and load gear prevents damage to hoist in the event of excessive overloading

OVERTRAVEL PROTECTION

- Low profile upper/lower limit switches need no adjustment. Protects hoist and allows for maximum travel.

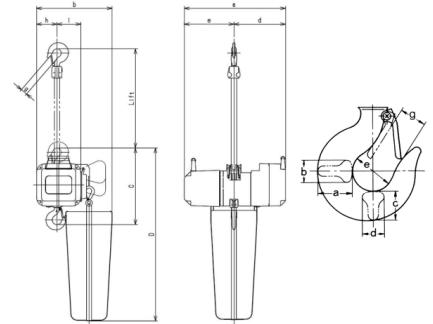

DIMENSIONS

Product Code	Minimum Headroom C (in)	L* (ft)	a (in)	b (in)	d (in)	e (in)	g (in)	h (in)	i (in)	D (in)
TNER005L	13.2	2.5	18.7	14.2	9.6	9.2	0.9	3.9	4.0	35.4
TNER010L	16.1	2.5	20.0	15.0	10.2	9.8	1.2	4.1	4.7	37.0
TNER020L	22.8	2.5	20.0	15.0	10.2	9.8	1.6	4.1	4.7	48.8
TNER010S	16.1	2.5	20.0	15.0	8.8	11.2	1.2	4.1	4.7	37.0
TNER020S	22.8	2.5	20.0	15.0	8.8	11.2	1.5	4.1	4.7	48.8
* Standard length of control and power cables unless otherwise specified.										
Hook Dimensions:										
Capacity Code	Hook	a	b	c	d	e	g			
005L	C	1.1	0.7	0.9	0.7	1.4	0.9			
005L	B	1.0	0.6	0.9	0.6	1.7	1.1			
010L/S	C	1.4	0.9	1.2	0.9	1.7	1.2			
010L/S	B	1.2	0.8	1.0	0.8	1.9	1.3			
020L/S	C	1.9	1.1	1.6	1.1	2.0	1.5			
020L/S	B	1.6	1.0	1.3	1.0	2.1	1.6			

SPECIFICATIONS

Capacity (tonne)	Model	Lifting Speed (ft/min)	Output (HP)	Motor Current Draw (amps)		Load Chain Wire Diameter (mm) x Chain Fall Lines	Load Sheave Pockets	Net Weight With 60 Feet of Lift (lbs)	Weight for One Additional FT. of Lift (lbs)
				220V or 440V	460V				
1/2 t	TNER005L	16	0.65	3.7	1.8	6.3 x 1	4	99	0.57
1 t	TNER010L	16	1.3	5.6	2.8	8.0 x 1	4	135	0.93
2 t	TNER020L	8	1.3	5.6	2.8	8.0 x 2	4	209	1.9
1 t	TNER010S	32	2.4	10.4	5.2	8.0 x 1	4	0	0.93
2 t	TNER020S	16	2.4	10.4	5.2	8.0 x 2	4	225	1.9

TNER SERIES

RELATED PRODUCTS