

# LX SERIES

## Small is the new huge.

Don't be fooled by its award winning pocket-sized design, the LX is no lightweight. Its robust integrated aluminum housing, tip supported hook latches, and heat treated gears and chain make this a small hoist that delivers huge durability and performance. And, with a 1mm lifting accuracy, the LX is capable of positioning your load exactly where you want it. Try it in either configuration: the LX 1/4t weighs in at only 4 lbs, making it the ideal lever hoist for work in tight quarters or elevated locations. Or try the LX 1/2t, which weighs in at only 6 lbs, for even more pulling power.

### Tough Aluminum Body and Steel Frame

Its lightweight and extremely compact aluminum body make the LX your ideal tool for elevated or difficult-to-reach places. Tools aren't always treated with the respect they deserve, which is why the durable steel frame provides long-lasting, high-strength support.

### Unmatched Precision Placement

A top choice for contracting or millwright professionals who need a precision placement tool that will lift, hold or tension a load to within millimetre accuracy. The LX requires very low force to lift loads and provides unmatched positioning capabilities when you need it most.

### Quick Free-Chain and Hook Positioning

Hook positioning is simple and safe with the integrated 2 step free-chain mechanism on the LX. You can easily switch from up or down mode to release the load from the hook and reposition in seconds.

### Abrasion and Corrosion-Resistant Load Chain

The standard grade 100 Nickel-Plated Chain on the LX is designed to stand up to abrasion and corrosion, which keeps your hoist working when you need it. It also withstands corrosive environments where damp air, steam and many acidic and alkaline solutions are prevalent.

### Award-Winning Pocket-Sized Design

Recognized and awarded for its pocket-sized design, the LX Mini Lever hoist is the go-to tool when you're looking for a mini lever hoist with a proven performance record. Take this hoist anywhere with its convenient carrying case with belt attachment.



# LX SERIES

---

## CAPACITY

- 1/4 to 1/2 metric tonnes

## STANDARDS

- ASME B30.21 Safety Standard
- ASME HST-3 Performance Standard
- At rated capacity, load bearing parts are stressed to 25% of their limit

## OPTIONS

- A carrying case can be attached to your belt for added convenience (LX003)
- Lift lengths can be customized to suit requirements

## BODY

- Durable die cast aluminum
- Steel internal frame
- Extremely compact, lightweight and portable. Designed for use in tight spaces

## HOOKS

- Forged, heat-treated alloy steel hooks open gradually, without fracturing under excessive load
- Top and bottom hooks equipped with self-closing heavy-duty hook latch
- Top and bottom hooks rotate 360 degrees

## LOAD CHAIN

- Abrasion- and corrosion-resistant nickel-plated finish
- Grade 100 heat-treated
- Standard Lift: 5 feet

## BRAKE

- Weston-style load brake
- Enclosed to protect from dust, rain and dirt

## GEARS

- Sealed gears and brake are protected against damage from dust and water

## OPERATION

- 360 degree handle rotation
- Rubber handle grip for non-slip operation
- Patented spring-loaded freewheel mechanism for easy adjustment of the load-chain and protection against accidental freewheeling under load
- Single-step reduction gearing for precision placement to within 1 mm.
- Induction heat-treated and case-hardened

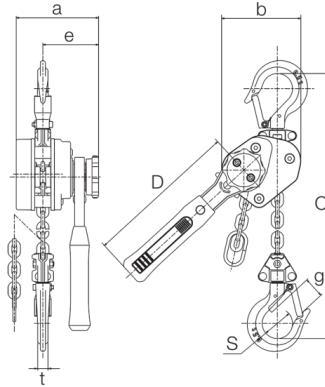

1/2 Metric Tonne

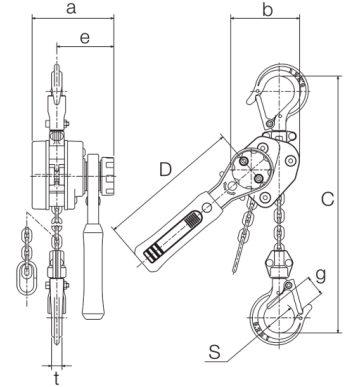

1/4 Metric Tonne

### DIMENSIONS

Capacity (tonne)	Model	D	a	b	e	g
1/4	LX003	150	89	74	61	21
1/2	LX005	181	100	94	69	23

### SPECIFICATIONS

Capacity (tonne)	Model	Standard Lift (ft)	Hand Pull to Lift Full Load (kg)	Headroom (in)	Handle Length (in)	Load Chain Code	Load Chain Falls	Ship Weight (lbs)	Weight per Additional 5ft of Lift (lbs)
1/4	LX003	3	20	8	6	KLX032	1	4	1
1/2	LX005	4	31	9.7	7	KLX043	1	6	2