

LB-SC SERIES

Protect your people and your investment.

The LB-SC lever hoist has all the benefits of the standard Kito LB but is equipped with an integrated slip clutch to help prevent injuries or damages on the job site. The slip clutch engagement is smooth and seamless with no erratic motion to make sure the load remains steady while lifting. Your people are safer and your hoist lasts longer with less down time for maintenance. That's why the LB-SC is increasingly becoming the trusted choice for heavy industry.

Unique Slip Clutch

Protecting the hoist and operator are essential. The unique slip clutch on the LB will engage when an excessive overload is detected keeping the load stationary and secure regardless of any additional hand force applied.

FAILSAFE FREEWHEEL SYSTEM

Our widely acclaimed fail-safe freewheel system closes the gap between operator safety and load control. Developed in-house 30 years ago, the freewheel mechanism was intentionally created as a two-step process to eliminate the risk of accidental free chaining. The result is dramatically improved functionality and operator safety.

Safety Tip Hook and Latch

Taking a hoist off-duty because of a damaged or broken hook latch is unacceptable. That's why the LB-SC latch was specifically designed to protect it from damage. The notch on the end of the latch is engineered to engage the tip of the hook to protect against lateral impact damage. The latch is also constructed of heavy gauge steel and secured by a widened anchor at the base to increase its rigidity.

State-Of-The-Art Chain Technology

Kito has successfully established a world-renowned reputation for manufacturing a lighter-weight, ultra-strong, high-performance load chain. What's more, the LB Grade 100 chain uses a shorter and narrower link profile for greater surface area contact, which improves wear resistance and overall tensile strength.

Structural Steel Side Plates

Regionalized heat-treated side plates provide extreme rigidity to maintain proper body shape and operational efficiency, no matter what the load is. This heat treatment process also prevents abrasion to the load chain during contact with the side plates. This functionality is another example of how Kito is committed to keeping the LB-SC working longer.



LB-SC SERIES

CAPACITY

- ¾ to 9 metric tonnes

STANDARDS

- ASME B30.21 Safety Standard
- ASME HST-3 Performance Standard
- At rated capacity, load-bearing parts are only stressed to 25% of their limit

OPTIONS

- Top hook extender
- Shipyard hook
- Inspection hook
- Black chain for heavy welding applications
- Custom lift lengths to suit your requirements

HOW THE SLIP CLUTCH WORKS

- The slip clutch engages when an excessive overload is detected
- The load remains stationary and secure regardless of any additional hand force applied
- This function stops the hoist from overloading and protects the hoist and operator from damage

BODY

- Rugged, high-impact stamped steel housing
- Compact and lightweight
- Open design for easy inspection and cleaning without dismantling the unit

HOOKS

- Forged, heat-treated alloy steel hooks open gradually without fracturing under excessive load
- Top and bottom hooks are equipped with self-closing heavy duty hook latches
- Top and bottom hooks rotate 360 degrees

OPERATION

- 360-degree handle rotation
- Rubber grip handle for non-slip operation
- Operate in close quarters with 15-degree recovery stroke
- Patented spring-loaded freewheel mechanism for easy adjustment of the load chain and protection against accidental freewheeling under load

GEARS

- Highly durable, split-load double reduction gears
- Induction heat-treated and case-hardened
- Enclosed to protect from dust and water

LOAD CHAIN

- Nickel plated as standard
- Grade 100 heat-treated
- Link Pitch: 2.8D
- Standard Lift: 5 feet
- Protective guard around the chain pin for enhanced safety

BRAKE

- Weston-style load brake with four braking surfaces, two brake pads and two brake pawls for added safety
- Five-star thread on brake ensures a level braking surface to ease load break-out

LB-SC

STEEL BODY LEVER HOIST - SLIP CLUTCH

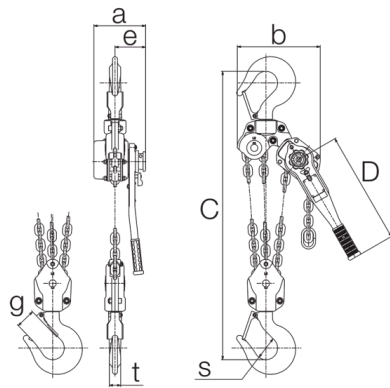

9 Metric Tonne

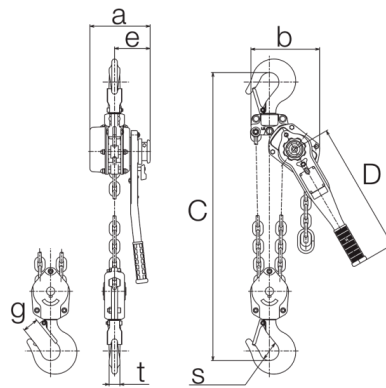

6 Metric Tonne

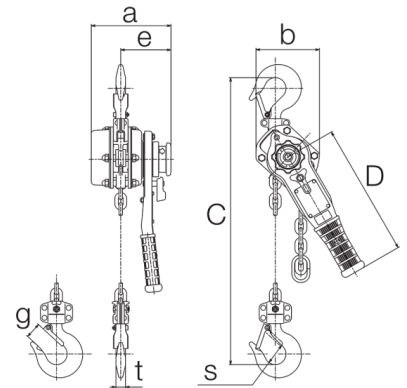

0.75 - 3 Metric Tonne

DIMENSIONS

Capacity (tonne)	Model	C	D	a	b	e	g	s	t
¾	L5LB008	280	245	144	119	97	23.5	35.5	14
1½	L5LB015	335	265	159	126	100	32	42.5	19
2½	L5LB025	375	265	173	150	102	36.5	47	21
3	L5LB030	395	415	190	159	112	39	50	24.5
6	L5LB060	540	415	190	217	112	50	60	34
9	L5LB090	680	415	190	304	112	72.5	85	41.5

SPECIFICATIONS

Capacity (tonne)	Model	Standard Lift (ft)	Hand Pull to Lift Full Load (kg)	Headroom (in)	Handle Length (in)	Load Chain Code	Load Chain Falls	Ship Weight (lbs)	Weight per Additional 5ft of Lift (lbs)
¾	L5LB008	5	27	11	9.75	KLB5056	1	13	3
1½	L5LB015	5	32	13.25	10.5	KLB5071	1	18	4
2½	L5LB025	5	37	14.75	10.5	KLB5088	1	26	6
3	L5LB030	5	35	15.5	16.5	KLB5100	1	35	8
6	L5LB060	5	36	21.25	16.5	KLB5100	2	59	16
9	L5LB090	5	39	26.75	16.5	KLB5100	3	92	24