

HCB SERIES

Gear changing that's game changing.

Save time and increase efficiency with the world's first dual speed manual chain hoist. Kito's innovative magnetic clutch technology senses the load and changes gears automatically to work seven times faster when repositioning an unloaded hook. The result is a significant reduction in labour costs and operator fatigue – something both your workers and your accountant will appreciate.

The First Clutch Of Its Kind

Work up to seven times faster and reduce operator fatigue during large capacity lifts. The HCB's innovative quick clutch technology detects torque as the operator pulls on the hand chain, which can reduce man-hours and related costs.

Safe, Reliable, Mechanical Brake

The HCB gives you added protection with its double pawl springs, providing redundancy and extra-reliable operation of the brake mechanism. With a double-enclosed brake cover, you can be sure that dust, rain and dirt are kept out, and that the mechanical brake activates instantly.

Efficient, Maintenance-Free Sealed Bearings

Low-maintenance features like sealed bearings protect from contamination and provide years of worry-free service. This contributes to the efficient drive chain and minimizes the manual effort required to operate.

Automatic Speed Control

In an unloaded or lightly loaded state, a magnetic clutch is automatically activated allowing the hoist to operate in high-speed mode. Once a load heavier than approximately 10 per cent of capacity is applied, the magnetic clutch releases and the standard clutch activates, putting the hoist back into standard-speed mode.

All-Steel Gear Case & Hand Wheel Cover

Increased strength and dependability can be expected from the HCB's rugged steel housing and double-steel plate construction. When your lifting application needs high performance and unmatched durability, the HCB delivers.



HCB SERIES

CAPACITY

- 2.5 to 50 metric tonnes

STANDARDS

- ASME B30.16 Safety Standard
- ASME HST-2 Performance Standard
- At rated capacity, load-bearing parts are only stressed to 25% of their limit

OPTIONS

- Chain bag to keep chain clean and out of the way
- Corrosion resistant chain for tough environments
- Custom lift lengths to suit your requirements
- Plain or Geared trolley mount

HIGH SPEED FEATURES

- When lightly loaded or unloaded, the load hook positioning is seven times faster than a standard CB
- Magnetic quick-clutch mechanism shifts gears automatically from high to low speed based on load

BODY

- Heavy-duty, high-impact steel construction
- Open load sheave for easy inspection and cleaning without dismantling the unit
- Rugged gear case and hand wheel cover
- Compact design for low headroom and lightweight portability

HAND CHAIN

- Design: High-quality steel

LOAD CHAIN

- Heat-treated, low-weight manganese alloy steel
- Grade 100
- High-impact steel chain guide
- Standard Lift: 8 feet

HOOKS

- Forged, non-tempered carbon steel hooks open gradually and do not fracture
- Self-closing top and bottom hooks with heavy-duty hook latch

OPERATION

- Hand-chain operated
- Reduced operator fatigue through efficient drive train

GEARS

- Double reduction gearing requiring very low effort to operate
- Induction heat-treated and case-hardened
- Enclosed to protect from dust and water

BEARINGS

- Maintenance-free sealed bearings increase reliability and reduce required pull force required to lift loads

BRAKE

- Safe, reliable mechanical brake activates instantly
- Double pawls for extremely reliable operation and instant brake activation
- Enclosed to protect from dust, rain and dirt

OPERATING CONDITIONS

- Recommended for -20° C to +60° C

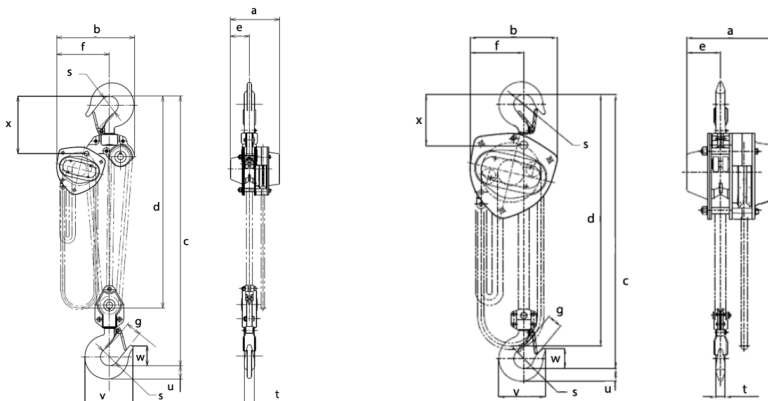

DIMENSIONS

Capacity (tonne)	Model	C	a	b	d	e	f	g	s	t	u	v	w	x
2½	HCB025	736.6	236	233	673	91	143	40	53	24.3	33.5	124	53	134
5	HCB050	914.4	237	282	704	91	194	46.5	63	34.5	47.5	159	66	174
7½	HCB075	1295.4	236	373	1012	91	143	72.5	85	47.5	63	229	95	276
10	HCB100	762	236	438	933	91	253	72.5	85	47.5	63	226	95	295.5
15	HCB150	1041.4	313	492	1012	119	337	80	100	60	80	271	108	320
20	HCB200	1193.8	464	746	1144	232	373	81	110	67	90	296	121	352

SPECIFICATIONS

Capacity (tonne)	Model	Standard Lift (ft)	Chain Pulled to Lift One Meter (m)		Load Chain Falls	Load Chain Code	Hand Chain Falls	Hand Pull to Lift Full Load (kg)	Load to Engage High Speed (tonne)	Headroom (in)	Ship Weight (lbs)	Weight per Additional 5ft of Lift (lbs)
			Unloaded	Loaded								
2½	HCB025	10	14	99	1	KCB3090	2	33	0.25 or less	17	75	9
5	HCB050	10	28	198	2	KCB3090	2	34	0.5 or less	24	106	15
7½	HCB075	12	42	297	3	KCB3090	2	35	0.7 or less	31	154	21
10	HCB100	12	56	396	4	KCB3090	2	36	0.9 or less	30	198	27
15	HCB150	12	85	594	6	KCB3090	2	37	1.3 or less	40	357	38
20	HCB200	12	56 x 2	396 x 2	8	KCB3090	4	36 x 2	1.8 or less	47	549	53