

ER2/MR2 Series Electric Chain Hoist (7.5t to 20t)

Parts List

Contents

Contents.....	2
Introduction	3
ER2 Electric Chain Hoist.....	4
Common Parts - Housing & Motor	4
Common Parts - Gearing	6
Common Parts - Chaining.....	8
Common Parts - Bottom Hook	10
Common Parts – Bottom Hook	12
Common Parts - Electric Components.....	14
Power Supply Cable, Push Button	16
Chain Container	18
Chain Container	20
Control Station and Cable - Plate Suspension Type.....	22
Top Suspension Plate Parts - Plate Suspension Type.....	26
Top Suspension Plate Parts - Plate Suspension Type.....	28
Control Station and Cable (Hook Type)	30
Top Hook (Hook Type)	34
MR2 Motorized Trolley.....	38
Motor / Gear related.....	38
Frame and Weel / Suspension shaft related.....	40
Push Button.....	44
Control Station and Cable - Plate Suspension Type(7.5t, 10t(L)).....	46
Control Station and Cable - Plate Suspension Type(7.5t, 10t(L)).....	50
Hanger Plate (Executive for 7.5t).....	54

Introduction

■ Target products

■ Product code

The parts lists show the related parts for the ER2 Series Electric Chain Hoist and the MR2 Series Motorized Trolley for large capacity. The types of the target products are as shown below. If you use manual trolley connection and are looking for trolley-related parts, refer to TS Manual Trolley Parts List for large capacity.

ER2			ER2 with MR2 (motorized trolley)		
Capacity (t)	Product code		Capacity (t)	Product code	
	Single speed model			Single speed model	
	Standard speed	Low speed		Standard speed	Low speed
7.5	ER2-075S		7.5	ER2M075S-L	
10	ER2-100S	ER2-100L	10	ER2M100S-L	ER2M100L-L
15	ER2-150S		15	ER2M150S-L	
20	ER2-200S		20	ER2M200S-L	

■ Product category and voltage

Product category	Motor insulation class	Voltage range	Operating voltage
		60Hz	
230/460V Class	B	220V	110V
		440V	
500V Class	B	575V	

■ Interpretation of parts lists

- (1) Match the number in the 3D diagram with "Figure No." in the parts list to obtain the part name.
- (2) Cells with an x-mark at intersection of Part name and product code in the parts table are not used.
- (3) Blank cells at the intersection of Part name and product code in the parts table vary the part number depending on the power supply voltage.

If you need a part for the blank cell, let us know the product code shown in the preceding item, power supply voltage and part number.

■ Load chain

- (1) Load chains are hardened chains. Therefore, they cannot be made longer.
- (2) When ordering a load chain, indicate the actual length or lifting height category.
- (3) Parts lists indicate the relation between the lifting height, winding margin, and actual length.

■ Push button cord complete set

When ordering a push button cord complete set, let us know the cord length referring to the following table.

Capacity	Push button cord length		
	ER2 with hook	ER2 with manual trolley	ER2 with MR2 (motorized trolley)
7.5t	-	Lift + 0.1m	Lift + 0.7m
10t (L)	-	Lift + 0.1m	Lift + 0.7m
10t (S)	Lift	Lift + 0.2m	Lift + 0.3m
15t	Lift + 0.2m	Lift + 0.6m	Lift + 0.6m
20t	Lift + 0.2m	Lift + 0.6m	Lift + 0.6m

■ How to order

- (1) When ordering, let us know the product code, voltage, Part name, Part number and quantity.
- (2) For part price and delivery date, contact our distributor or KITO.

Common Parts - Housing & Motor

ER2-075S/ER2-100L/ER2-100S/ER2-150S/ER2-200S

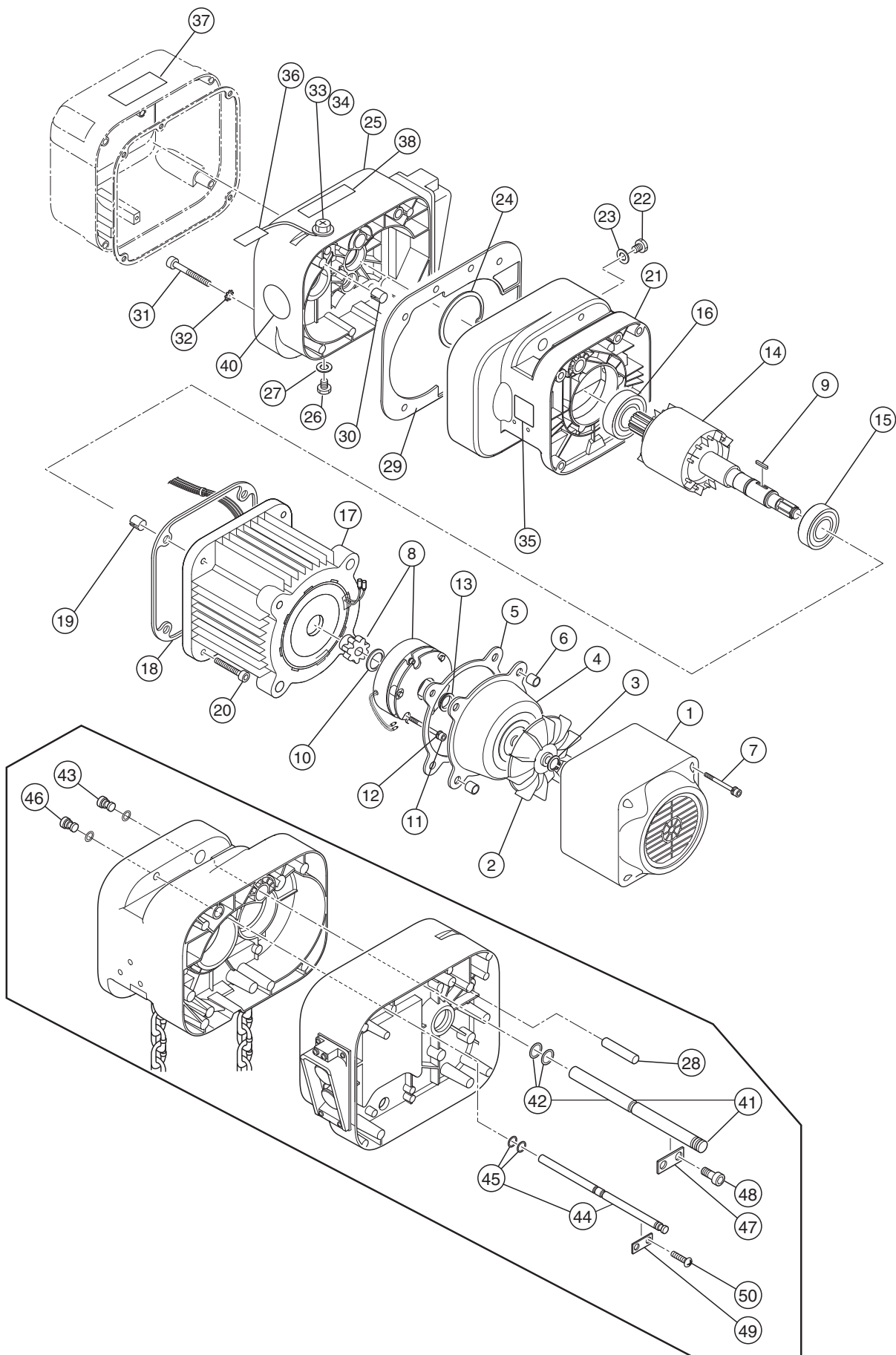

ER2-075S/ER2-100L/ER2-100S/ER2-150S/ER2-200S

Figure No.	Part Number	Part Name	Quantity per hoist					ER2-F					Remark
			ER2-075S	ER2-100L	ER2-100S	ER2-150S	ER2-200S	ER2-075S	ER2-100L	ER2-100S	ER2-150S	ER2-200S	
1	107	Fan cover	1		2			ER2ES9107	←	←	←	←	
2	108	Fan	1		2			ER2ES9108	←	←	←	←	
3	323	Snap ring	1		2			J1SS000-00022	←	←	←	←	For fan
4	115	Brake cover	1		2			ER2ES9115	←	←	←	←	
5	119	Packing B	1		2			ER2ES9119	←	←	←	←	
6	140	Set pin S	2		4			E6SE005S9120	←	←	←	←	For fan cover, brake cover
7	160	Socket bolt	4		8			J1BE1-0604524	←	←	←	←	For fan cover, brake cover
8	1362	Electromagnetic brake assembly	1		2								With hub spring
9	360	Key B	1		2			ER2ES9360	←	←	←	←	For electromagnetic brake
10	361	Snap ring	1		2			J1SS000-00030	←	←	←	←	For electromagnetic brake
11	167	Socket bolt	3		6			J1BE1-0805028	←	←	←	←	For electromagnetic brake
12	168	Spring lock washer	3		6			J1WS011-20100	←	←	←	←	For electromagnetic brake
13	210	V ring	1		2			ER2ES9210	←	←	←	←	Packing between motor shaft and brake cover
14	5502	Motor shaft with rotor	1		2			ER2FS5502	←	←	←	←	
15	202	Ball bearing	1		2			J1GR050-06007	←	←	←	←	For motor frame
16	208	Ball bearing	1		2			J1GR050-06006	←	←	←	←	For bearing holder (for motor shaft)
17	5501	Motor frame with stature	1		2								
18	118	Packing M	1		2			ER2FS9118	←	←	←	←	For motor frame
19	138	Set pin S	2		4			ER2ES9138	←	←	←	←	For motor frame
20	155	Socket bolt	4		8			J1BE1-1204040	←	←	←	←	For motor frame
21	101	Body B	1		2			ER2FS9101	←	←	←	←	Dedicated body for friction
22	133	Oil plug	1		2			E5FE003S9111	←	←	←	←	
23	136	Plug packing	1		2			E2YS005-9109	←	←	←	←	For oil plug
24	207	Snap ring	1		2			J1SR000-00080	←	←	←	←	
25	103	Gear case	1		2			ER2FS9103	←	←	←	←	
26	133	Oil plug	1		2			E5FE003S9111	←	←	←	←	For gear case
27	136	Plug packing	1		2			E2YS005-9109	←	←	←	←	For oil plug
28	139	Spring pin	1		2			J1PS11-060025	←	←	←	←	
29	116	Packing G	1		2			ER2FS9116	←	←	←	←	For gear case
30	137	Set pin S	2		4			E6SE010S9120	←	←	←	←	For gear case
31	151	Socket bolt	5		10			J1BE1-0809028	←	←	←	←	For gear case
32	152	Toothed lock washer	5		10			J1WH012-10080	←	←	←	←	For gear case
33	135	Oil plug B	1		2			ER1BS9135	←	←	←	←	For gear case F
34	173	Eyebolt packing	1		2			E2YS005-9116	←	←	←	←	For oil plug B
35	960	Name plate load side	1		2			ER1BS9960	←	←	←	←	Load side
36	953	Oil Full tag	1		2			ER1BS9953	←	←	←	←	Oil full
37	935	Warning sticker E	1		2								Danger: Be aware of electric shock
38	810	Name plate OF	1		2								Warning: specific oil for friction
40	868	Name plate AD	1		2								Speed display
41	6121	Top pin assembly	1		2			ER2FS6121	←	←	←	←	For body connection
42	126	O ring	2		4			J1OP011-00180	←	←	←	←	
43	6128	Top pin plug assembly	1		2			ER2FS6128	←	←	←	←	
44	6122	Fixing shaft assembly	1		2			ER2FS6122	←	←	←	←	
45	127	O ring	2		4			J1OP011-00090	←	←	←	←	
46	6131	Fixing shaft plug assembly	1		2			ER2FS6131	←	←	←	←	
47	123	Plate A	1		2			ER1ES9123	←	←	←	←	For top pin
48	124	Machine screw socket bolt	2		4			J1BG1-0601616	←	←	←	←	For plate A (top pin)
49	125	Plate A	1		2			ER1BS9123	←	←	←	←	For fixing shaft
50	143	Machine screw with spring washer	2		4			J1AP2-5001212	←	←	←	←	For plate A (fixing shaft)

Common Parts - Gearing

ER2-075S/ER2-100L/ER2-100S/ER2-150S/ER2-200S

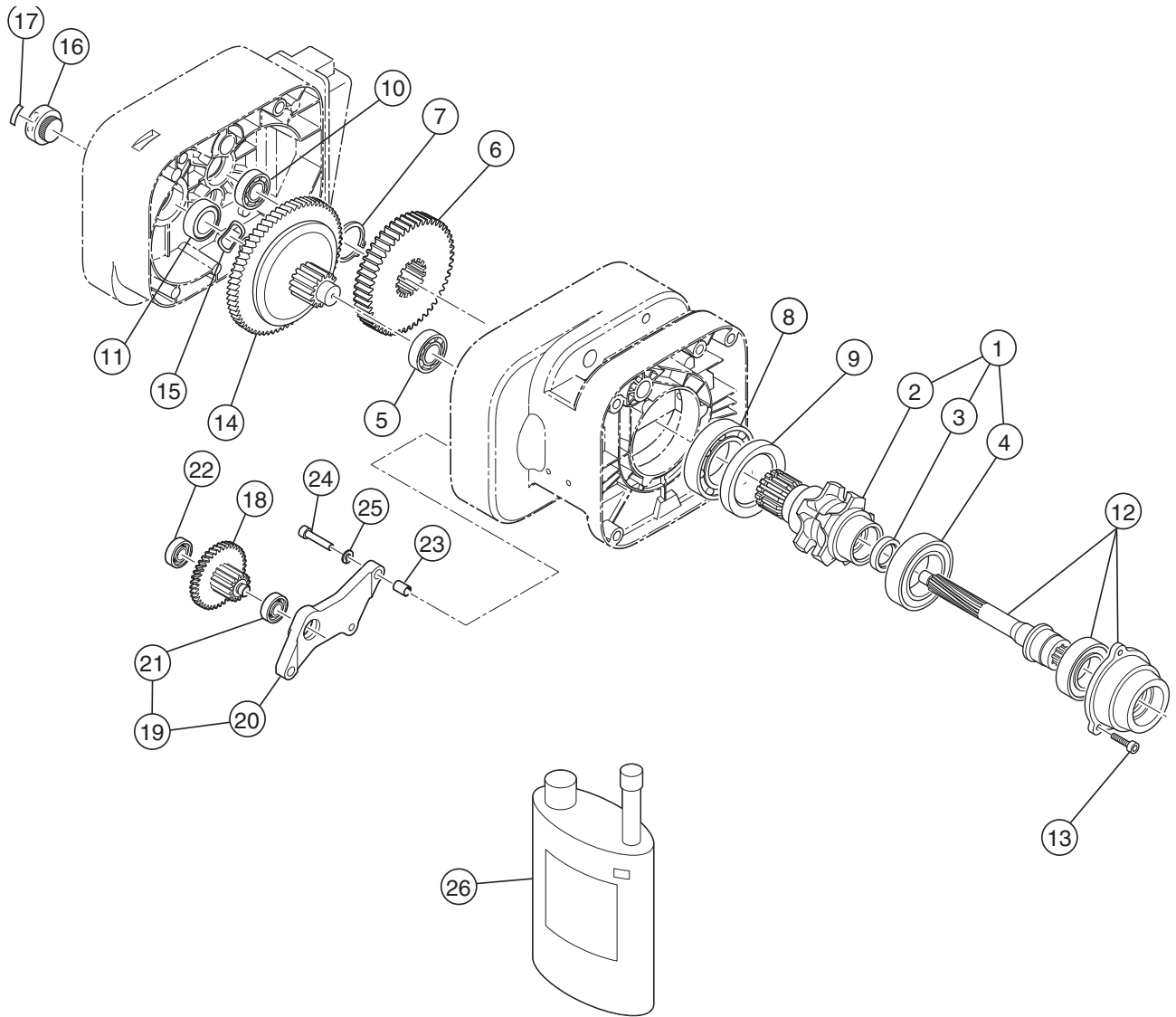

ER2-075S/ER2-100L/ER2-100S/ER2-150S/ER2-200S

Figure No.	Part Number	Part Name	Quantity per hoist					ER2-F					Remark
			ER2-075S	ER2-100L	ER2-100S	ER2-150S	ER2-200S	ER2-075S	ER2-100L	ER2-100S	ER2-150S	ER2-200S	
1	6241	Load sheave assembly	1		2			ER2FS6241	←	←	←	←	
2	241	Load sheave	1		2			ER2FS9241	←	←	←	←	
3	221	Oil seal	1		2			ER2ES9221	←	←	←	←	For pinion
4	242	Ball bearing	1		2			J1GR020-06210	←	←	←	←	For load sheave (motor side)
5	238	Ball bearing	1		2			J1GR000-06405	←	←	←	←	For gear #3 (body side)
6	240	Load gear	1		2			ER2FS9240	←	←	←	←	
7	245	Snap ring	1		2			J1SS000-00050	←	←	←	←	For load gear
8	243	Ball bearing	1		2			J1GR000-06010	←	←	←	←	For load sheave (gear case side)
9	244	Oil seal	1		2			ER2ES9244	←	←	←	←	For load sheave (gear case side)
10	222	Ball bearing	1		2			J1GR000-06303	←	←	←	←	For pinion (gear case side)
11	233	Oil seal	1		2			ER1DS9233	←	←	←	←	For seal collar
12	5220	Pinion assembly	1		2			ER2FS5220	←	←	←	←	
13	164	Socket bolt	3		6			J1BE1-0601616	←	←	←	←	For bearing holder
14	1223	Friction clutch complete set	1		2			ER2HS1223	ER2IL1223	ER2FR1223	ER2HS1223	ER2IL1223	
15	234	Wave washer	1		2			ER2ES9234	←	←	←	←	
16	235	Nut cover	1		2			ER2ES9235	←	←	←	←	
17	840	Name plate FP	1		2								Danger: Adjustment of friction nut not allowed
18	5262	Gear B assembly	1		2			ER2FS5262	←	←	←	←	
19	6261	Gear holder plate assembly	1		2			ER2FS6261	←	←	←	←	
20	261	Gear holder plate	1		2			ER2FS9261	←	←	←	←	
21	264	Ball bearing	1		2			J1GR000-06203	←	←	←	←	
22	266	Ball bearing	1		2			J1GR000-06202	←	←	←	←	Gear B (gear case side)
23	270	Set pin S	2		4			E6SE010S9126	←	←	←	←	For gear holder plate
24	271	Socket bolt	3		6			J1BE1-0803535	←	←	←	←	For gear holder plate
25	272	Spring lock washer	3		6			J1WS011-20080	←	←	←	←	For gear holder plate
26	1855	Oil pot F (1L)	2		4			ER1CS1855	←	←	←	←	For friction clutch specification

Common Parts - Chaining

ER2-075S/ER2-100L/ER2-100S/ER2-150S/ER2-200S

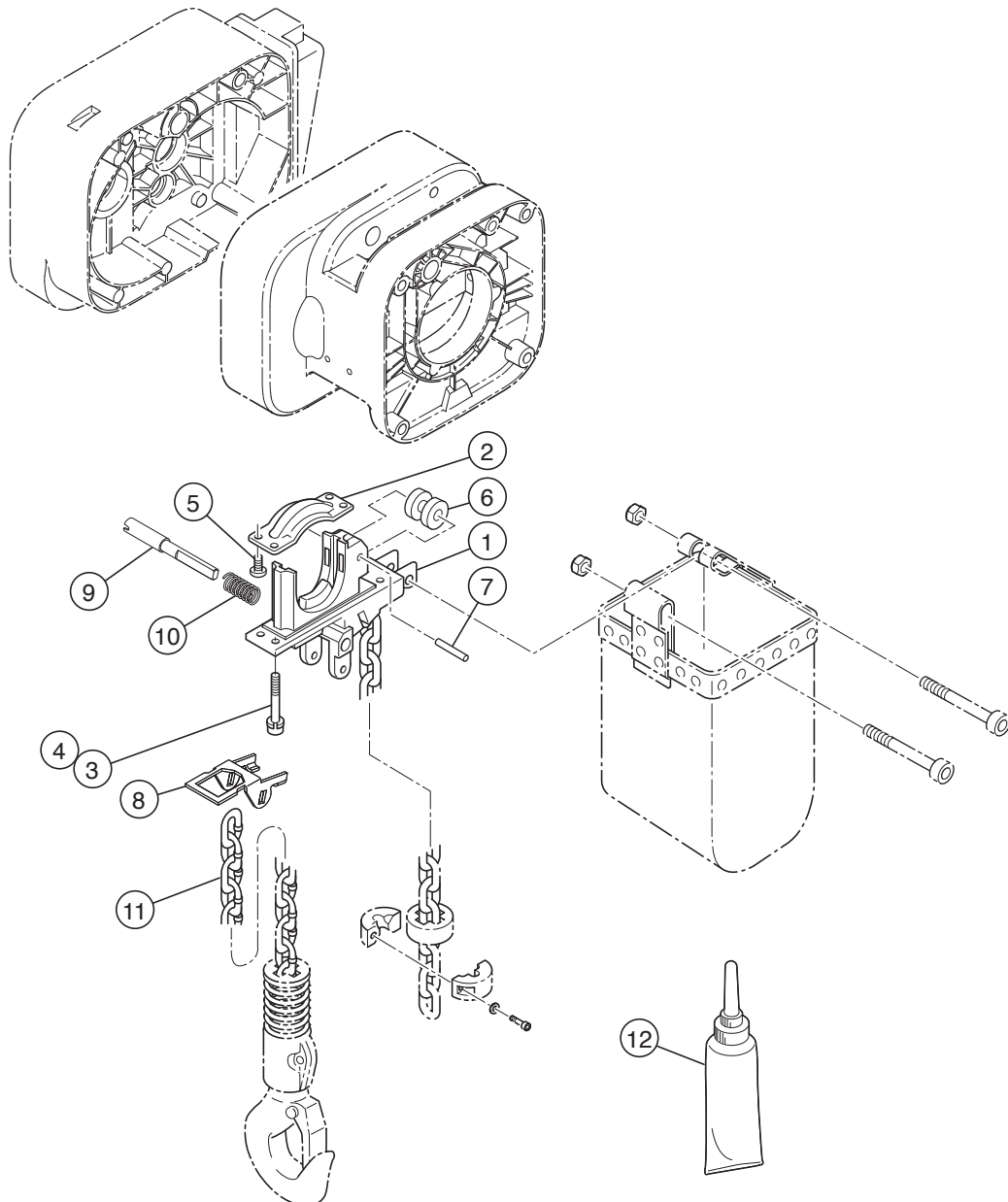

ER2-075S/ER2-100L/ER2-100S/ER2-150S/ER2-200S

Figure No.	Part Number	Part Name	Quantity per hoist					ER2-F					Remark
			ER2-075S	ER2-100L	ER2-100S	ER2-150S	ER2-200S	ER2-075S	ER2-100L	ER2-100S	ER2-150S	ER2-200S	
1	331	Chain guide A	1		2			ER2FS9331	←	←	←	←	
2	332	Chain guide B	1		2			ER2FS9332	←	←	←	←	
3	346	Socket bolt	4		8			J1BE1-0803030	←	←	←	←	For chain guide A
4	347	Spring lock washer	4		8			J1WS011-20080	←	←	←	←	For chain guide A
5	348	Machine screw with spring washer	4		8			J1AP2-6001212	←	←	←	←	For chain guide B
6	333	Guide roller	1		2			ER1EM9333	←	←	←	←	
7	334	Roller pin	1		2			ER1DL9334	←	←	←	←	
8	337	Limit lever	1		2			ER2FS9337	←	←	←	←	
9	338	Limit lever pin	1		2			ER2FS9338	←	←	←	←	
10	357	Limit lever spring	1		2			ER2CS9357	←	←	←	←	
11	954	NC load chain (short pitch)	1		2			KBAN112W0000	←	←	←	←	
	955	ND load chain (short pitch)					KBFA112W0000						
12	1951	Lubricant tube assembly	2		2			ER2CS1951	←	←	←	←	

Common Parts - Bottom Hook

ER2-075S/ER2-100L/ER2-100S

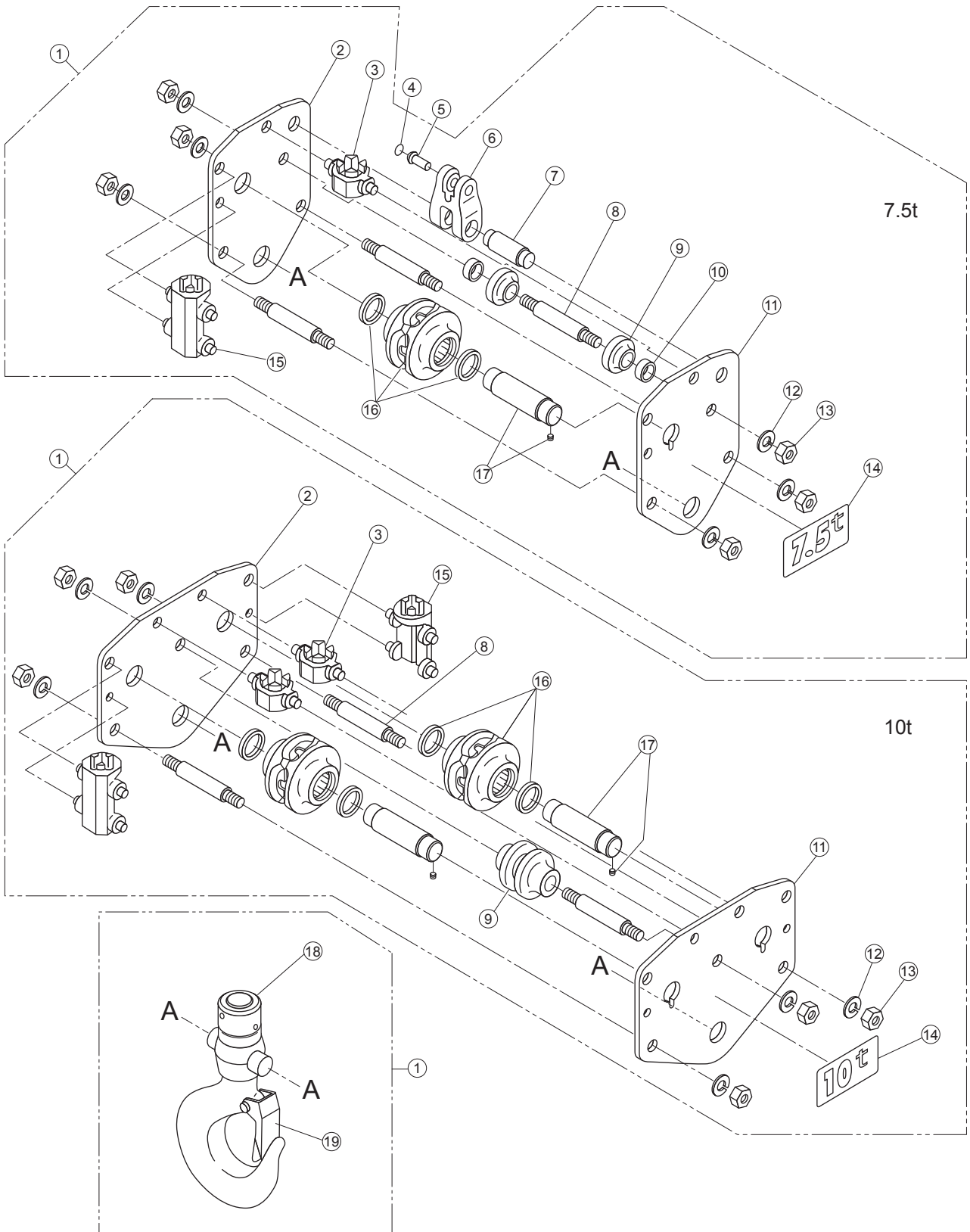

ER2-075S/ER2-100L/ER2-100S

Figure No.	Part Number	Part Name	Quantity per hoist			ER2-F			Remark
			ER2-075S	ER2-100L	ER2-100S	ER2-075S	ER2-100L	ER2-100S	
1	1121	Bottom hook complete set	1	←	←	ER2HS1121	ER2IS1121	←	
2	035	Bottom suspension plate B	1	←	←	ER2HS9035	ER2IS9035	←	
3	067	Bottom cross guide	1	2	←	E6SE075S9067	←	←	
4	092	Snap ring	1	←	←	J1SR000-00021	X	X	
5	041	Chain pin	1	←	←	S2SB030-9107	X	X	
6	039	Chain holder	1	←	←	E6SE075S9039	X	X	
7	040	Chain holder pin	1	←	←	E6SE075S9040	X	X	
8	038	Bottom stay bolt	3	←	←	E7SE075S9038	←	←	
9	062	Guide roller	2	←	←	E6SE075S9062	X	X	
	063	Bottom guide roller	X	1	←	X	E6SE100S9063	←	
10	065	Bottom collar	2	←	←	E6SE075S9065	X	X	
11	034	Bottom suspension plate A	1	←	←	ER2HS9034	ER2IS9034	←	
12	082	Spring washer	6	←	←	J1WS011-20200	←	←	For bottom stay bolt
13	081	Nut	6	←	←	J1NA001-30200	←	←	For bottom stay bolt
14	069	Name plate A	1	←	←	ER1HS9069	ER1IS9069	←	
15	066	Bottom chain guide	1	2	←	E6SE075S9066	←	←	
16	5052	Bottom idle sheave assembly	1	2	←	ER2HS5052	←	←	
17	5054	Bottom shaft assembly	1	2	←	E6SE075S5054	←	←	
18	2121	Bottom hook assembly	1	←	←	ER2HS2121	ER2IS2121	←	
19	071	Lever assembly	1	←	←	C2BA100-1071	C2BA150-1071	←	

Common Parts – Bottom Hook

ER2-150S/ER2-200S

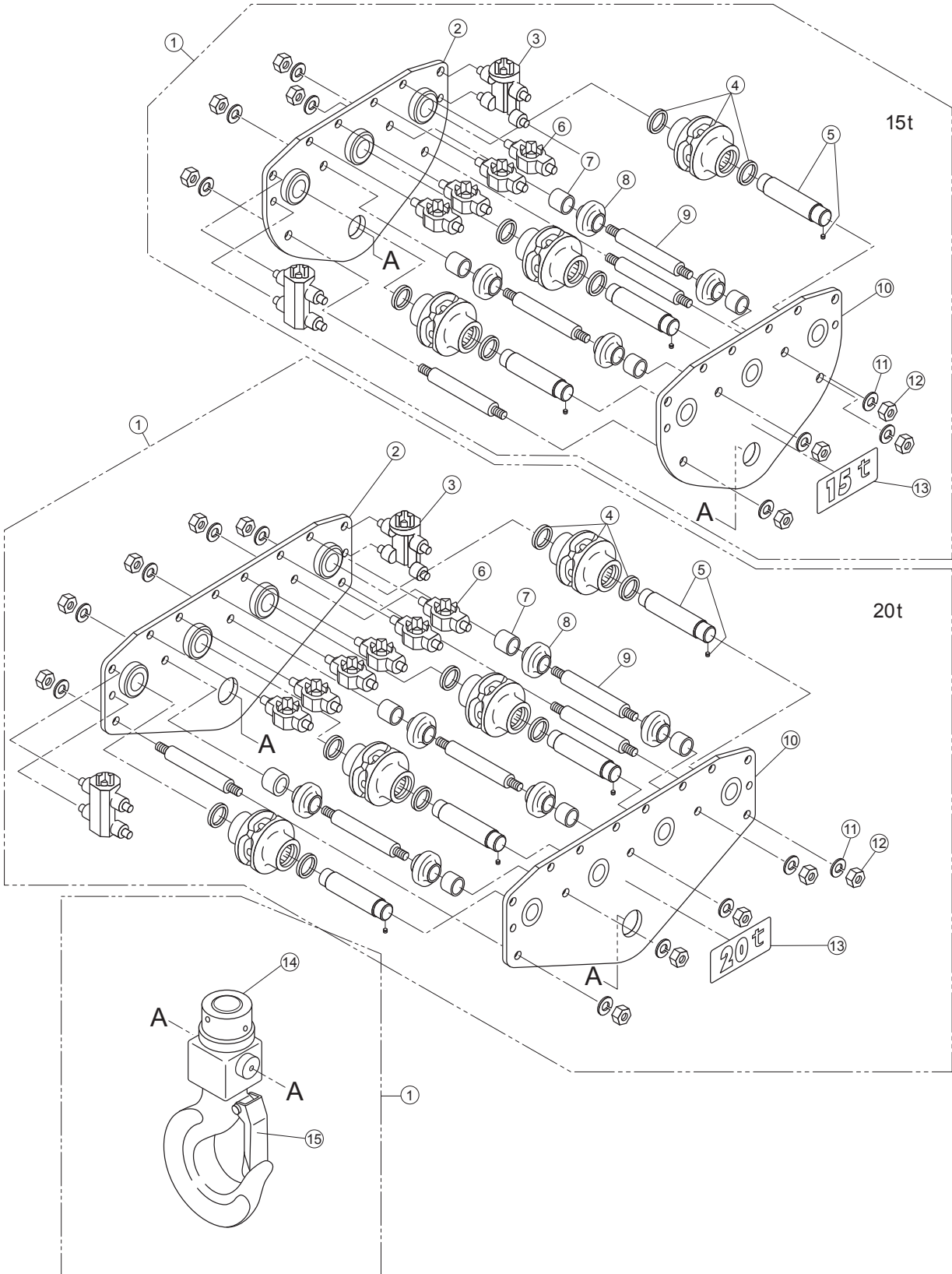

Common Parts – Bottom Hook

ER2-150S/ER2-200S

Figure No.	Part Number	Part Name	Quantity per hoist		ER2-F		Remark
			ER2-150S	ER2-200S	ER2-150S	ER2-200S	
1	1121	Bottom hook complete set	1	1	ER2JS1121	ER2KS1121	
2	5035	Bottom suspension plate B assembly	1	1	ER2JS5035	ER2KS5035	
3	066	Bottom chain guide	2	2	E6SE150S9066	←	
4	5052	Bottom idle sheave assembly	3	4			
5	5054	Bottom shaft assembly	3	4			
6	067	Bottom cross guide	4	6	E6SE150S9067	←	
7	065	Bottom collar	4	6	E6SE150S9065	←	
8	062	Guide roller	4	6	E6SE075S9062	←	
9	038	Bottom stay bolt	4	7	E7SE150S9038	←	
10	5034	Bottom suspension plate A assembly	1	1	ER2JS5034	ER2KS5034	
11	082	Spring washer	8	14			For bottom stay bolt
12	081	Nut	8	14			For bottom stay bolt
13	069	Name plate A	1	1	ER1JS9069	ER1K16	
14	2121	Bottom hook assembly	1	1	ER2JS2121	ER2KS2121	
15	071	Lever assembly	1	1	C2BA200-1071	C2BA300-1071	

Common Parts - Electric Components

ER2-075S/ER2-100L/ER2-100S/ER2-150S/ER2-200S

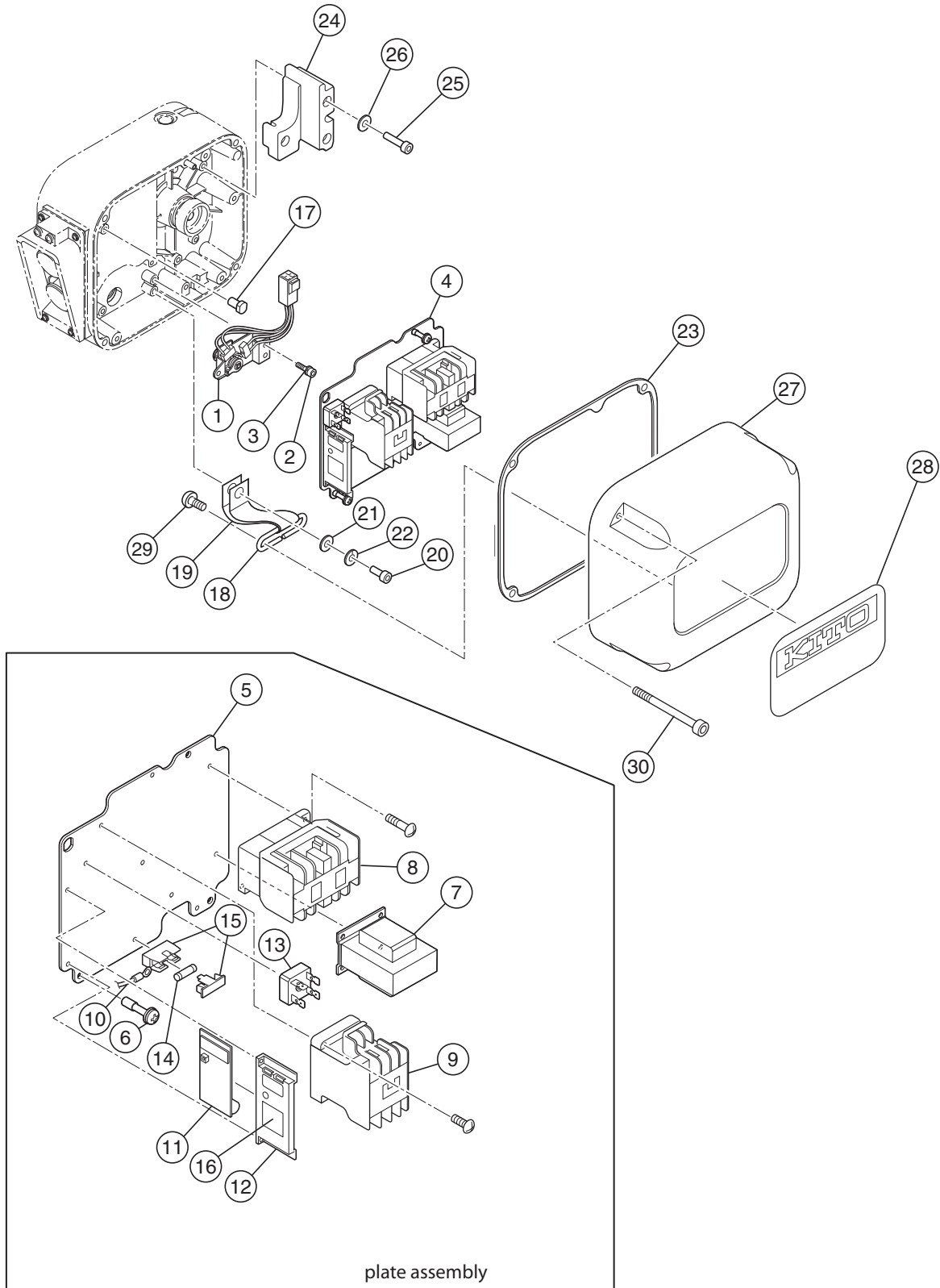

ER2-075S/ER2-100L/ER2-100S/ER2-150S/ER2-200S

Figure No.	Part Number	Part Name	Quantity per hoist					ER2-F					Remark
			ER2-075S	ER2-100L	ER2-100S	ER2-150S	ER2-200S	ER2-075S	ER2-100L	ER2-100S	ER2-150S	ER2-200S	
1	1060	Limit switch complete set	1		2			ER2C11060	←	←	←	←	
2	353	Socket bolt	3		6			J1BE1-0601212	←	←	←	←	For limit switch
3	354	Spring lock washer	3		6			J1WS011-20060	←	←	←	←	For limit switch
4	1441	Plate assembly	1		2								
5	441	Plate	1		2			ER2ES9441	←	←	←	←	
6	445	Plate screw	3		6			ER1BS9445	←	←	←	←	
7	577	Transformer	1		2								
8	578	Electromagnetic contactor	1		2								For forward/reverse switching
9	580	Electromagnetic contactor	1		2								For emergency stop
10	583	Lead wire	1		2								
11	582	CH meter	1		2								
12	597	CH meter support	1		2			ECP99BKBA	←	←	←	←	
13	598	Rectifier	1		2			ECP94DIAA	←	←	←	←	
14	602	Fuse	1		2			ECP91FZ02	←	←	←	←	
15	603	Fuse holder	1		2			ECP92FZAA	←	←	←	←	
16	838	Name plate CH	1		2			ECP99CHAA					
17	449	Fulcrum pin	1		2			ER2CS9449	←	←	←	←	Plate rotation center pin
18	456	Cover suspender	1		2			ER2CS9456	←	←	←	←	
19	457	Cover belt	1		2			ER2CS9457	←	←	←	←	
20	458	Socket bolt	1		2			J1BE1-0601616	←	←	←	←	For cover belt (attached to gear case)
21	459	Plain washer	1		2			ER1BS9436	←	←	←	←	For cover belt (attached to gear case)
22	460	Spring lock washer	1		2			J1WS011-10060	←	←	←	←	For cover belt (attached to gear case)
23	117	Packing C	1		2			ER2FS9117	←	←	←	←	For controller cover
24	109	Balancer	1		2			ER2FS9109	←	←	←	←	
25	162	Socket bolt	3		6			J1BE1-0802525	←	←	←	←	For balancer
26	163	Spring lock washer	3		6			J1WS011-20080	←	←	←	←	For balancer
27	104	Controller cover	1		2			ER2FS9104	←	←	←	←	
28	800	Name plate B	1		2				←	←	←	←	
29	114	Pan head machine screw	2		4			J1AK2-5001212	←	←	←	←	For cover suspender (attached to controller cover)
30	153	Machine screw socket bolt	4		8			J1BG1-0604024	←	←	←	←	For controller cover

Power Supply Cable, Push Button

ER2-075S/ER2-100L/ER2-100S/ER2-150S/ER2-200S

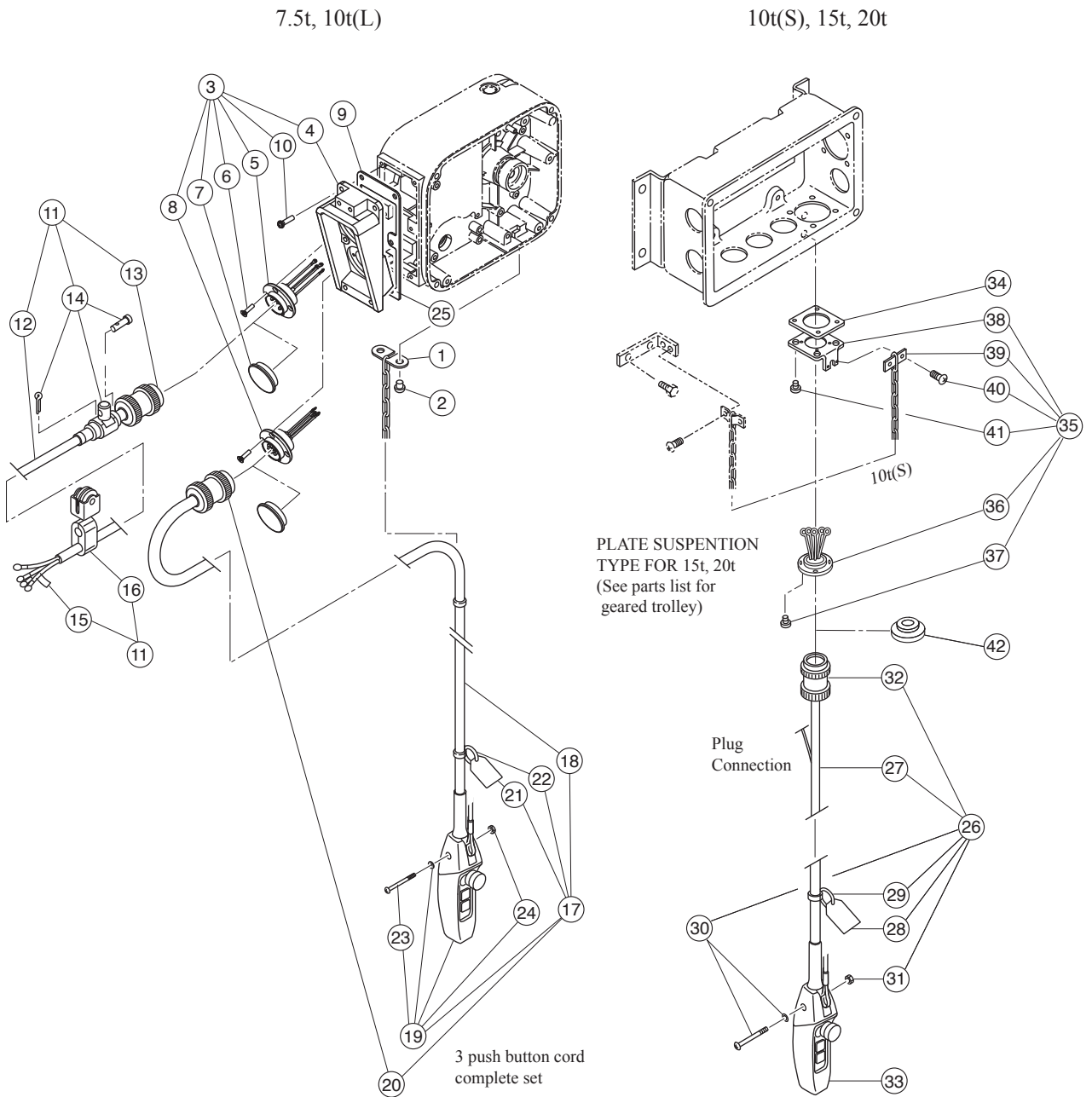

ER2-075S/ER2-100L/ER2-100S/ER2-150S/ER2-200S

7.5t, 10t(L)

Figure No.	Part Number	Part Name		075S	100L	Note
1	535	Cord support L (for chain)	1	ER1BS9534	←	
2	536	Machine screw with spring washer	2	J1AP2-5001212	←	
3	1511	Socket frame complete set	1			
4	511	Socket frame	1	ER2CS9511	←	
5	1523	Socket 4P assembly	1			
6	537	Tapping flat head machine screw	8	E6SE003S9551	←	
7	538	Socket cover	2			
8	1564	Socket 8P assembly	1			
9	512	Socket frame packing	1	ER2CS9512	←	
10	516	Machine screw with spring washer	6	J1AP2-5002020	←	
11	1771	Power supply cable 4C assembly	1			
12	771	Power supply cable 4C	1			
13	522	Plug 4P	1			
14	1724	Cable support 16 assembly	1			
15	741	Name plate G	1	E6LE010S9806	E6LE010S9806	
16	1641	Cable hanger 15/17 assembly	1			
17	1557	Push button cord 4C assembly	1			
18	557	Push button cord 4C	1			
19	1561	3 push button switch assembly	1			
20	566	Plug 8P	1			
21	567	Warning tag PB	1	SED9013AA	←	
22	568	Tag holder	1	E7SE003S9787	←	
23	569	Machine screw	1	J1AP2-4002608	←	
24	570	Nut	1	J1NS004-10040	←	
25	000	Steel plate	1			

10t(S), 15t, 20t

Figure No.	Part Number	Part Name		100S	150S	200S	Note
26	1557	Push button cord 4C assembly	1				
27	557	Push button cord 4C	1				
28	567	Warning tag PB	1	SWD9013AE	SWD9013AE	←	
29	568	Tag holder	1	E7SE003S9787	←	←	
30	569	Machine screw with spring washer	1	J1AP2-4002608	←	←	
31	570	Nut	1	J1NS004-10040	←	←	
32	566	Plug 8P	1				
33	1561	3 push button switch assembly	1				
34	818	Cord cover packing	1	M7SE010S9527	←	←	
35	1811	Socket 8P complete set	1				
36	5811	Socket 8P assembly	1				
37	814	Tapping flat head machine screw	4	J1AL2-4001212	←	←	
38	815	Socket holder	1	M6ME010S9529	←	←	
39	816	Cord chain stopper	1	M6FE005S9530	←	←	
40	817	Machine screw with spring washer	2	J1AP2-5001010	←	←	
41	820	Machine screw with spring washer	4	J1AP2-5001010	←	←	
42	819	Socket cover 4P	1				

For power supply cable of 10t (s), 15t, and 20t, see p22-24 and p30-32.

Chain Container

ER2-075S/ER2-100L

7.5t

10t(L)

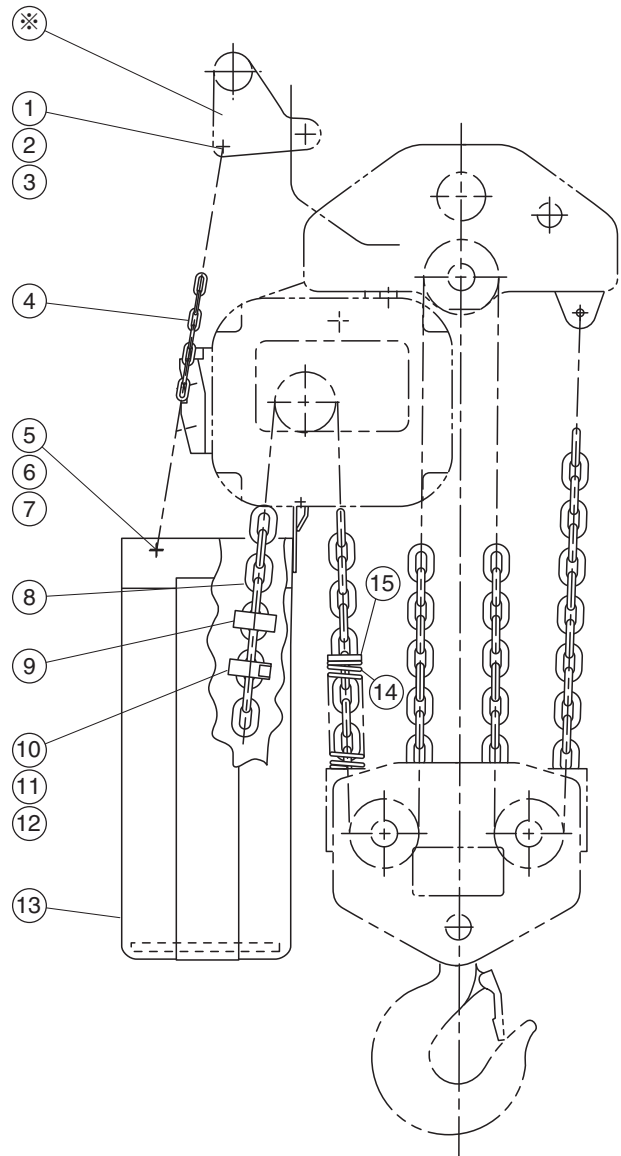
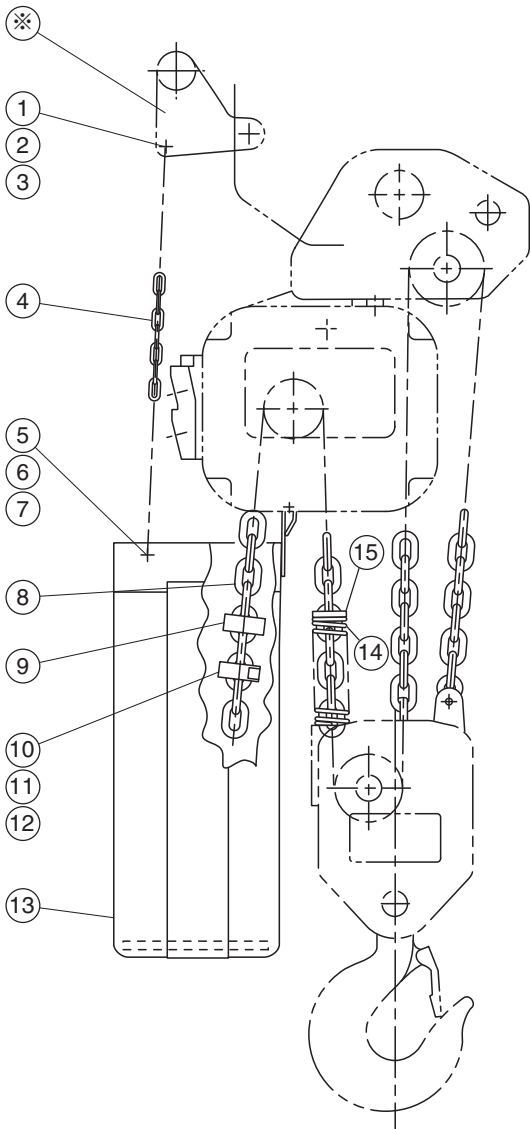

ER2-075S/ER2-100L

Plate suspension type

Figure No.	Part Number	Part Name		075S	100L	Note
1	981	Socket bolt	1	J1BE1-0803030	←	For container chain
2	983	Lever nut	2	C2BA100-9074	←	For container chain
3	984	Washer	2	J1WB012-10080	←	For container chain
4	975	Container chain	2	E6SE075S9875	←	
5	971	Socket bolt	2	J1BE1-0802020	←	
6	973	Lever nut	2	C2BA100-9074	←	
7	974	Washer	2	J1WB012-10080	←	
8	954	NC load chain (short pitch)	1	KBAN112W0000	←	
	955	ND load chain (short pitch)	1	KBFA112W0000	←	
9	049	Cushion rubber	1	ER1EM9053	←	Non-load side
10	045	Stopper	2	ER1ES9041	←	
11	090	Socket bolt	2	J1BE1-0802525	←	For stopper
12	091	Spring washer	2	J1WS011-20080	←	For stopper
13	5930	Chain container (H1) assembly	1	ER2HS5930	←	
	5931	Chain container (H2) assembly		ER2HS5931	←	
14	047	Chain spring	1	E6SE025B9047	←	Load side
15	048	Limiting plate	1	ER1FH9054	←	Load side

Hook type

Figure No.	Part Number	Part Name		075S	100L	Note
1	981	Socket bolt	1	X	J1BE1-0806528	For container chain
2	983	Lever nut	1	X	C2BA100-9074	For container chain
4	975	Container chain	2	X	E6SE100S9875	
5	971	Socket bolt	2	X	J1BE1-0802020	
6	973	Lever nut	2	X	C2BA100-9074	
7	974	Washer	2	X	J1WB012-10080	
8	954	NC load chain (short pitch)	1	X	KBAN112W0000	
	955	ND load chain (short pitch)	1	X	KBFA112W0000	
9	049	Cushion rubber	1	X	ER1EM9053	Non-load side
10	045	Stopper	2	X	ER1ES9041	
11	090	Socket bolt	2	X	J1BE1-0802525	For stopper
12	091	Spring washer	2	X	J1WS011-20080	For stopper
13	5930	Chain container (H1) assembly	1	X	ER2HS5930	
	5931	Chain container (H2) assembly		X	ER2HS5931	
14	047	Chain spring	1	X	E6SE025B9047	Load side
15	048	Limiting plate	1	X	ER1FH9054	Load side

Chain Container

ER2-100S/ER2-150S/ER2-200S

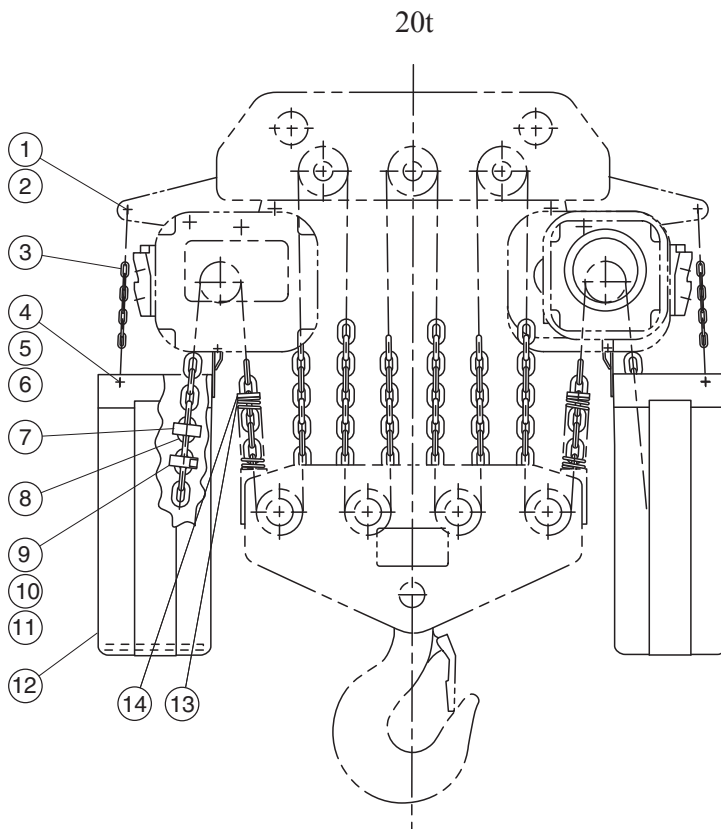
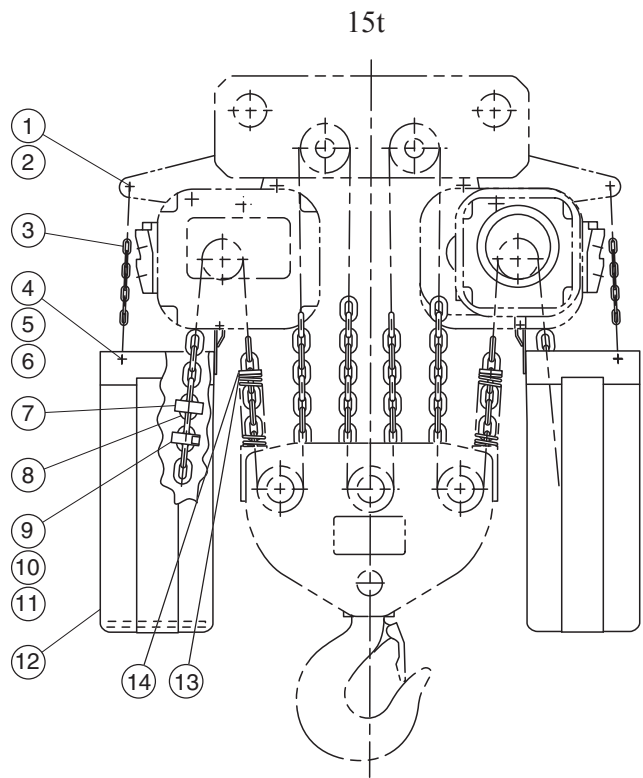
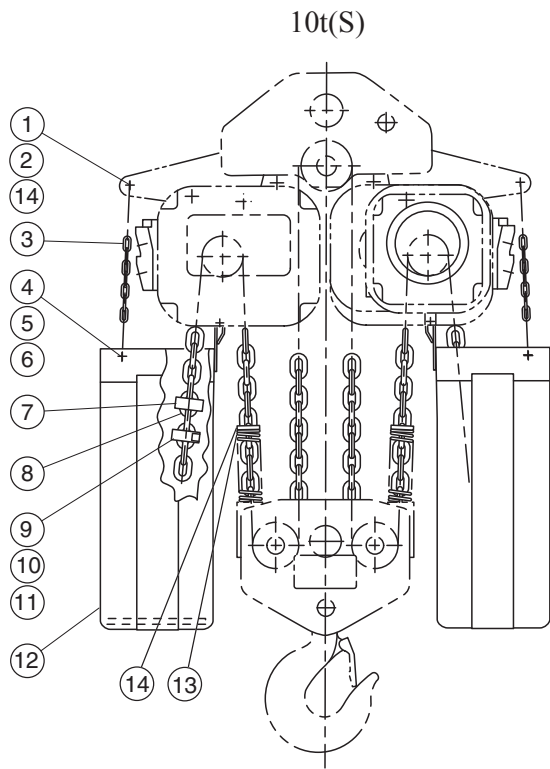

ER2-100S/ER2-150S/ER2-200S

Plate suspension and hook type

Figure No.	Part Number	Part Name		100S	150S	200S	Note
1	981	Socket bolt	2	J1BE1-0806528	←	←	For container chain
2	983	Lever nut	2	C2BA100-9074	←	←	For container chain
3	975	Container chain	4	E6SE100S9875	←	←	
4	971	Socket bolt	4	J1BE1-0802020	←	←	
5	973	Lever nut	4	C2BA100-9074	←	←	
6	974	Washer	4	J1WB012-10080	←	←	
7	049	Cushion rubber	2	ER1EM9053	←	←	Non-load side
8	954	NC load chain (short pitch)	1	KBAN112W0000	←	←	
	955	ND load chain (short pitch)	1	KBFA112W0000	←	←	
9	045	Stopper	4	ER1ES9041	←	←	
10	090	Socket bolt	4	J1BE1-0802525	←	←	For stopper
11	091	Washer	4	J1WS011-20080	←	←	For stopper
12	5930	Chain container (H1) assembly	2	ER2HS5930	←	←	
	5931	Chain container (H2) assembly		ER2HS5931	←	←	
13	047	Chain spring	2	E6SE025B9047	←	←	Load side
14	048	Limiting plate	2	ER1FH9054	←	←	Load side

Control Station and Cable - Plate Suspension Type

ER2-100S/ER2-150S/ER2-200S

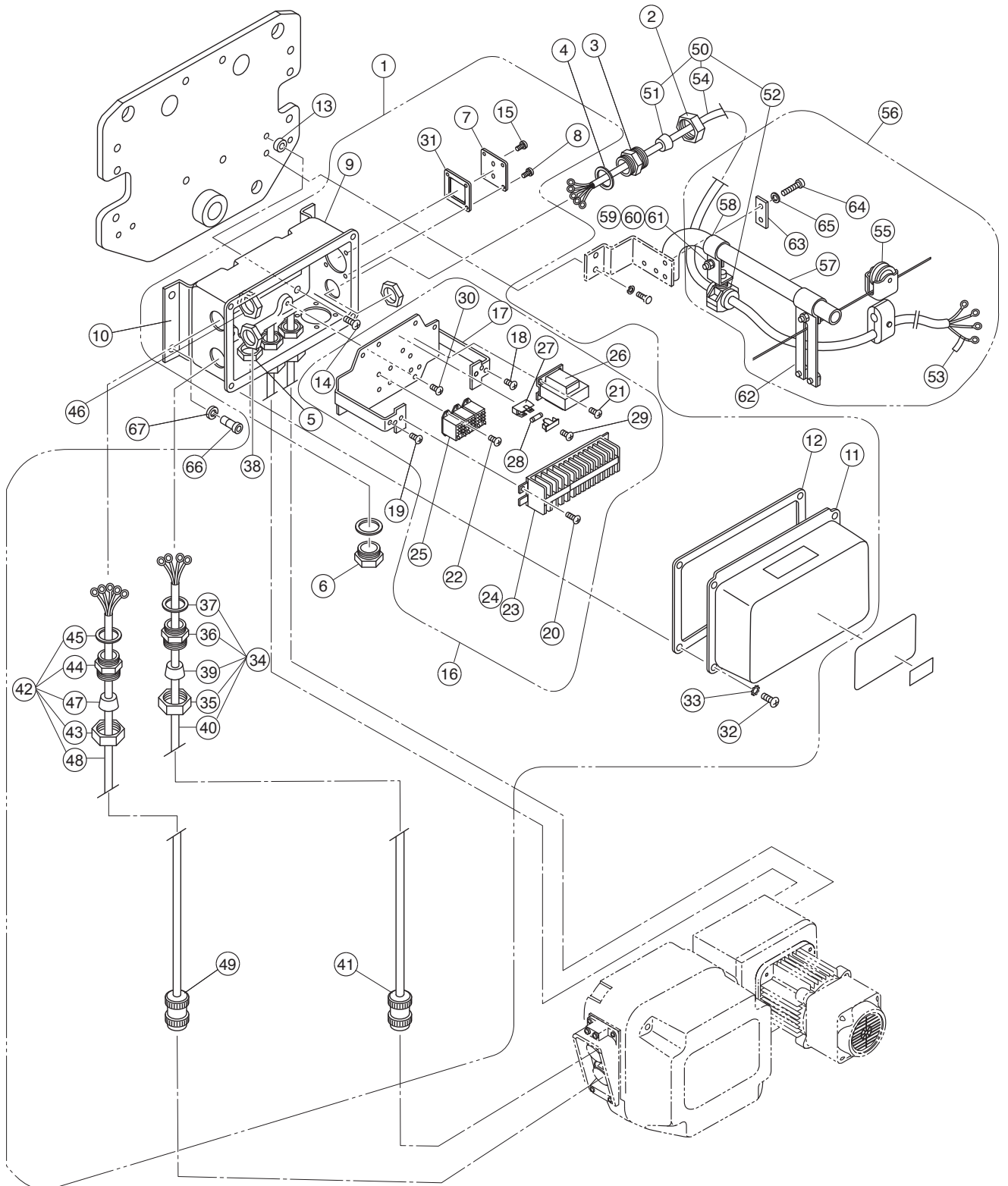

Control Station and Cable - Plate Suspension Type

ER2-100S/ER2-150S/ER2-200S

Suspension type

Figure No.	Part Number	Part Name		100S	150S, 200S	Note
1	1401	Connection box complete set	1			
2	341	Holder A	1	ECP5924AA	←	
3	342	Holder B	1	ECP5924AB	←	
4	343	Packing	2	ECP5924AC	←	
5	344	Holder nut	2	ECP5924AD	←	
6	345	Holder cap	1	ECP5924AE	←	
7	347	Cord cover	1	ER1IS9347	←	
8	348	Machine screw with spring washer	4	J1AP2-5001010	←	For Cord cover
9	401	Connection box	1	MR1IS9401	←	
10	405	Connection box holder	1	MR1HS9405	←	
11	411	Connection box cover	1	MR1DS9411	←	
12	421	Connection box packing	1	MR1DS9421	←	
13	423	Spacer	4	M6SE010S9517	←	
14	424	Machine screw with spring washer	4	J1AP2-8001414	←	For Connection box holder
15	432	Machine screw with spring washer	2	J1AP2-6001010	←	
16	1445	Plate complete set	1			
17	5445	Plate assembly	1	MR2IS5445	←	
18	450	Machine screw with spring washer	1	J1AP2-5000808	←	
19	451	Machine screw with spring washer	3	J1AP2-4000808	←	For ground
20	452	Machine screw with spring washer	2	J1AP2-5001010	←	For Terminal
21	455	Machine screw with spring washer	2	J1AP2-4000808	←	For Transformer
22	461	Machine screw with spring washer	6	J1AW2-3000808	←	For Relay
23	853	Terminal 16P	1	ECP1610AA	←	
24	863	Lead wire	1set			
25	876	Relay	3	MGC42C26A	←	
26	881	Transformer	1	TRF32K611	←	
27	891	Fuse holder	1	ECP92FZAA	←	
28	892	Fuse	1	ECP91FZ01	←	
29	894	Machine screw with spring washer	1	J1AP2-3000808	←	For Fuse holder
30	454	Machine screw with spring washer	4	J1AP2-5001010	←	For Plate assembly
31	818	Cord cover packing	1	M7SE010S9527	←	
32	422	Machine screw with spring washer	4	J1AP2-5001010	←	For connection box cover
33	425	Toothed lock washer	4	J1WH012-10050	←	For Connection box cover
34	1751	Relay cable 4C assembly	2			For Power supply
35	341	Holder A	2	ECP5924AA	←	
36	342	Holder B	2	ECP5924AB	←	
37	343	Packing	2	ECP5924AC	←	
38	344	Holder nut	2	ECP5924AD	←	
39	351	Cable packing	2	ECP6916AA	←	
40	751	Relay cable 4C	2			
41	752	Plug 4P	2	ECP2304AF	←	
42	1761	Relay cable 4C assembly	2			For operation
43	341	Holder A	2	ECP5924AA	←	
44	342	Holder B	2	ECP5924AB	←	
45	343	Packing	2	ECP5924AC	←	
46	344	Holder nut	2	ECP5924AD	←	
47	351	Cable packing	2	ECP6916AA	←	
48	761	Relay cable 4C	2			
49	752	Plug 4P	2	ECP2108AC	←	
50	1771	Power supply cable 4C assembly	2	ZBZC12BH2000	←	
51	351	Cable packing	2	ECP6918AA	←	

Figure No.	Part Number	Part Name		100S	150S, 200S	Note
52	1724	Cable support 19 assembly	2	ECP5900CA	←	
53	741	Name plate G	2	E6LE010S9806	←	
54	771	Power supply cable 4C	1			
55	1641	Cable hanger 17 assembly	n	M7NE010S1108	←	
	1641	Cable hanger 15 assembly	n	X	M3YS010-17332	
56	1491	Cable support bar complete set	1	MR1DS1491	←	
57	491	Cable support bar	1	MR1DS9491	←	
58	492	Cable support arm	1	MR1DS9492	←	
59	497	Bolt	2	J1BA2-0802525	←	
60	498	Spring lock washer	2	J1WS012-20080	←	
61	499	Nut	2	J1NA002-20080	←	
62	1493	Wire guide assembly	1	MR1DS1493	←	
63	501	Support bar holder (plate)	1	MR1DS9501	←	
64	505	Bolt	2	J1BA2-0803030	←	
65	506	Spring lock washer	2	J1WS012-20080	←	
66	406	Socket bolt	4	J1BE1-0802020	←	For connection box holder
67	407	Spring lock washer	4	J1WS011-20080	←	For connection box holder

Top Suspension Plate Parts - Plate Suspension Type

ER2-075S/ER2-100L/ER2-100S

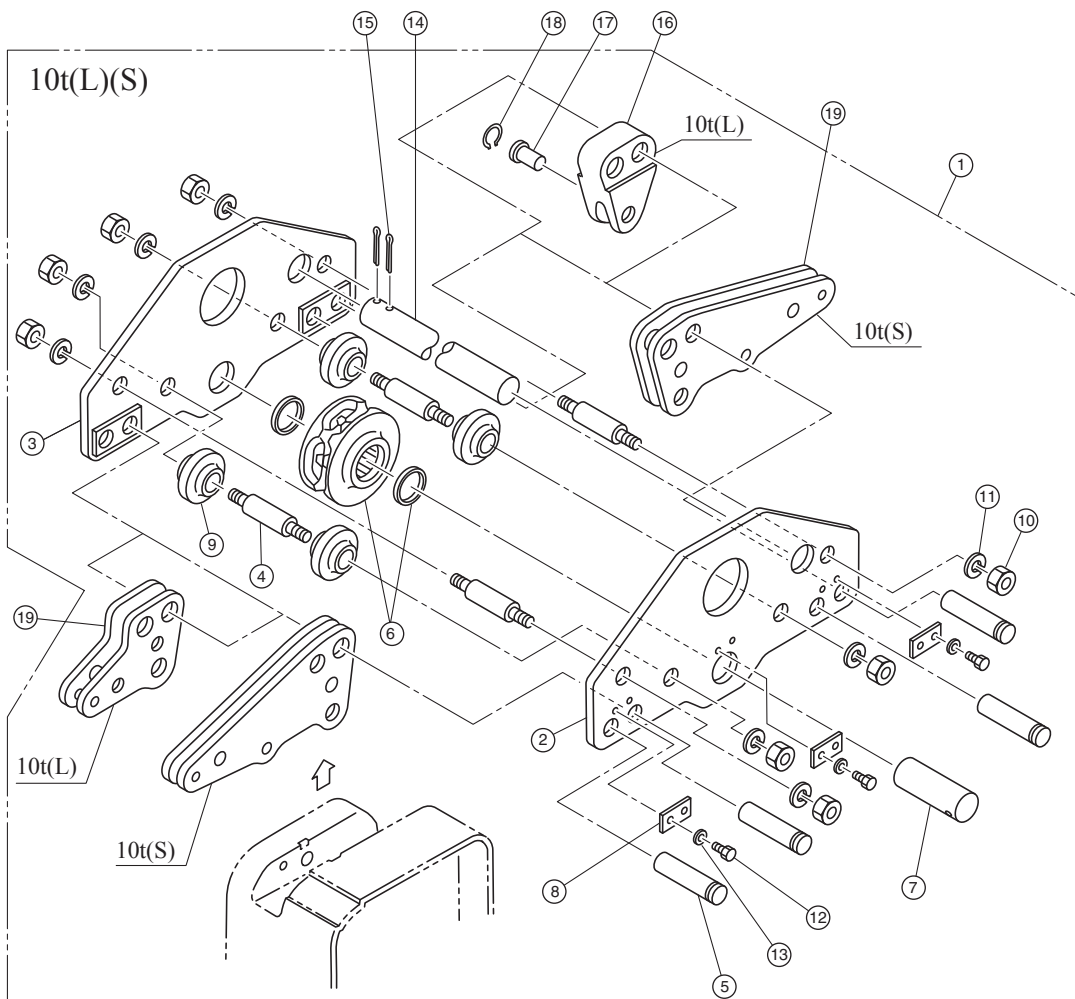
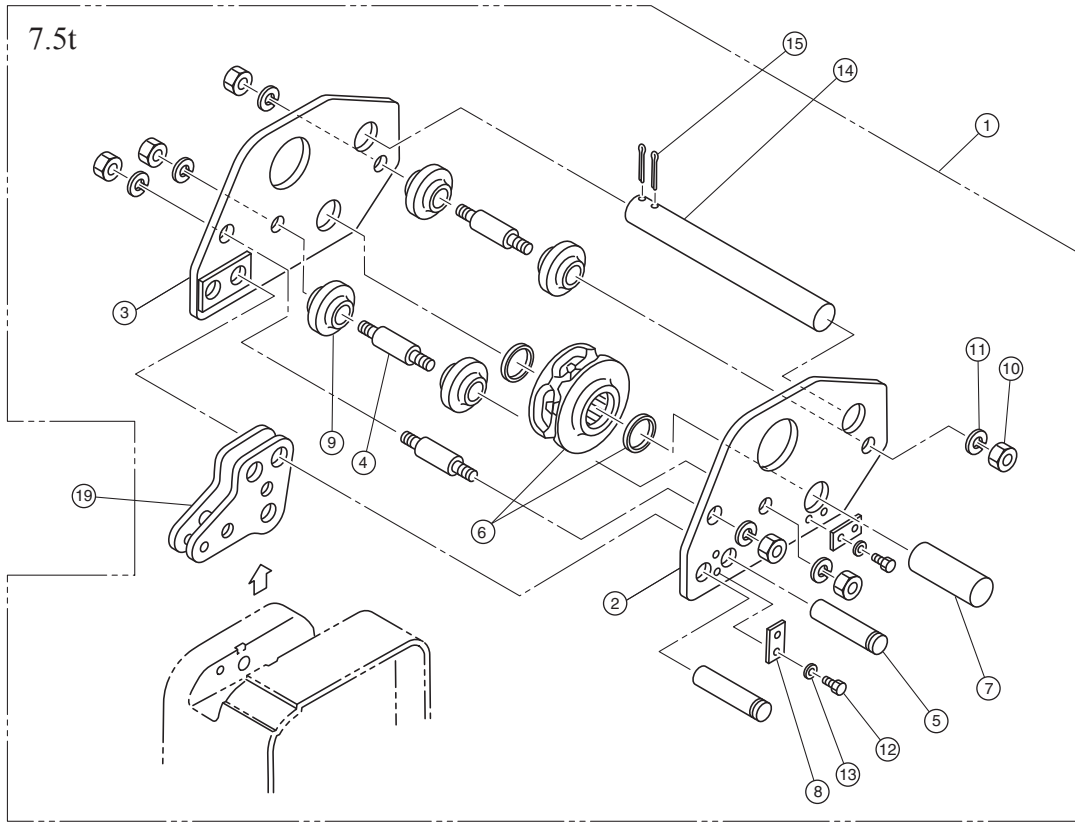

Top Suspension Plate Parts - Suspension Type

ER2-075S/ER2-100L/ER2-100S

Figure No.	Part Number	Part Name	075S		100L		100S		Note
1	1003	Top suspension plate assembly	ER2HS1003	1	ER2IS1003	1	←	1	
2	5003	Top suspension plate A assembly	ER2HS5003	1	ER2IS5003	1	←	1	
3	5004	Top suspension plate B assembly	ER2HS5004	1	ER2IS5004	1	←	1	
4	007	Top stay bolt	E7SE075S9007	3	←	4	←	4	
5	008	Suspension shaft	E6SE075S9008	2	←	4	←	4	
6	5051	Top idle sheave assembly	ER2HS5051	1	←	1	←	1	
7	053	Top shaft	E6SE075S9053	1	←	1	←	1	
8	056	Shaft stopper A	ER1HS9056	2	←	3	←	3	
9	062	Guide roller	E6SE075S9062	4	←	4	←	4	
10	081	Nut	J1NA001-30200	6	←	8	←	8	For top stay bolt
11	082	Spring washer	J1WS011-20200	6	←	8	←	8	For top stay bolt
12	083	Socket bolt	J1BE1-0801616	4	←	6	←	6	For shaft stopper A
13	084	Spring washer	J1WS011-20080	4	←	6	←	6	For shaft stopper A
14	010	Fixing shaft	E6SE075S9010	1	←	1	←	1	
	018	Fixing shaft (300)	E7SE075S9019	1	←	1	←	1	
15	089	Sprit pin	J1PW01-050050	2	←	2	←	2	For fixing shaft
16	017	Chain holder	X		ER1IL9017	1	X	1	For the end of load-side chain
17	041	Chain pin	X		S2SB030-9107	1	X	1	For the end of load-side chain
18	092	Snap ring	X		J1SR000-00021	1	X	1	For chain pin
19	5005	Connection yoke assembly	ER2HS5005	1	←	1	ER2IS5005	2	

Top Suspension Plate Parts - Plate Suspension Type

ER2-150S/ER2-200S

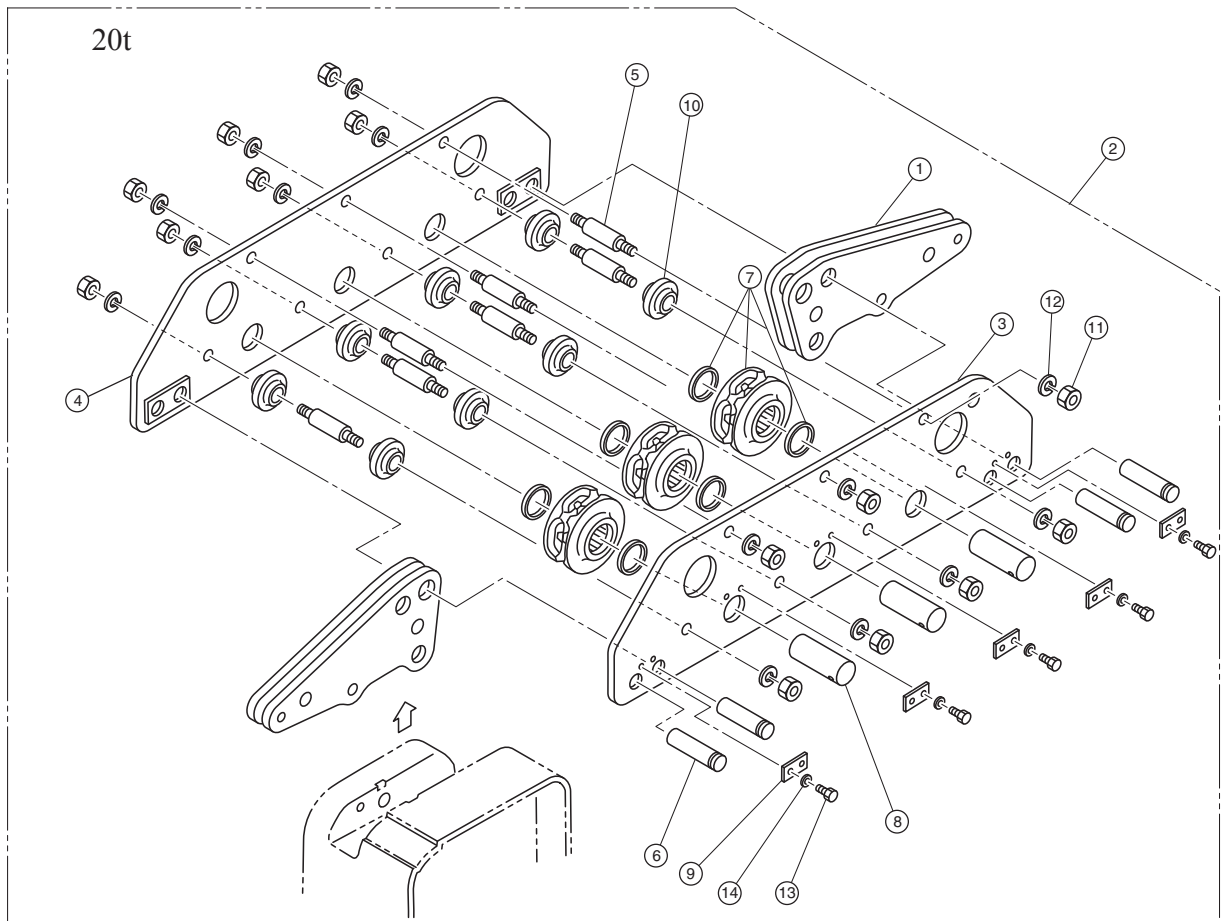
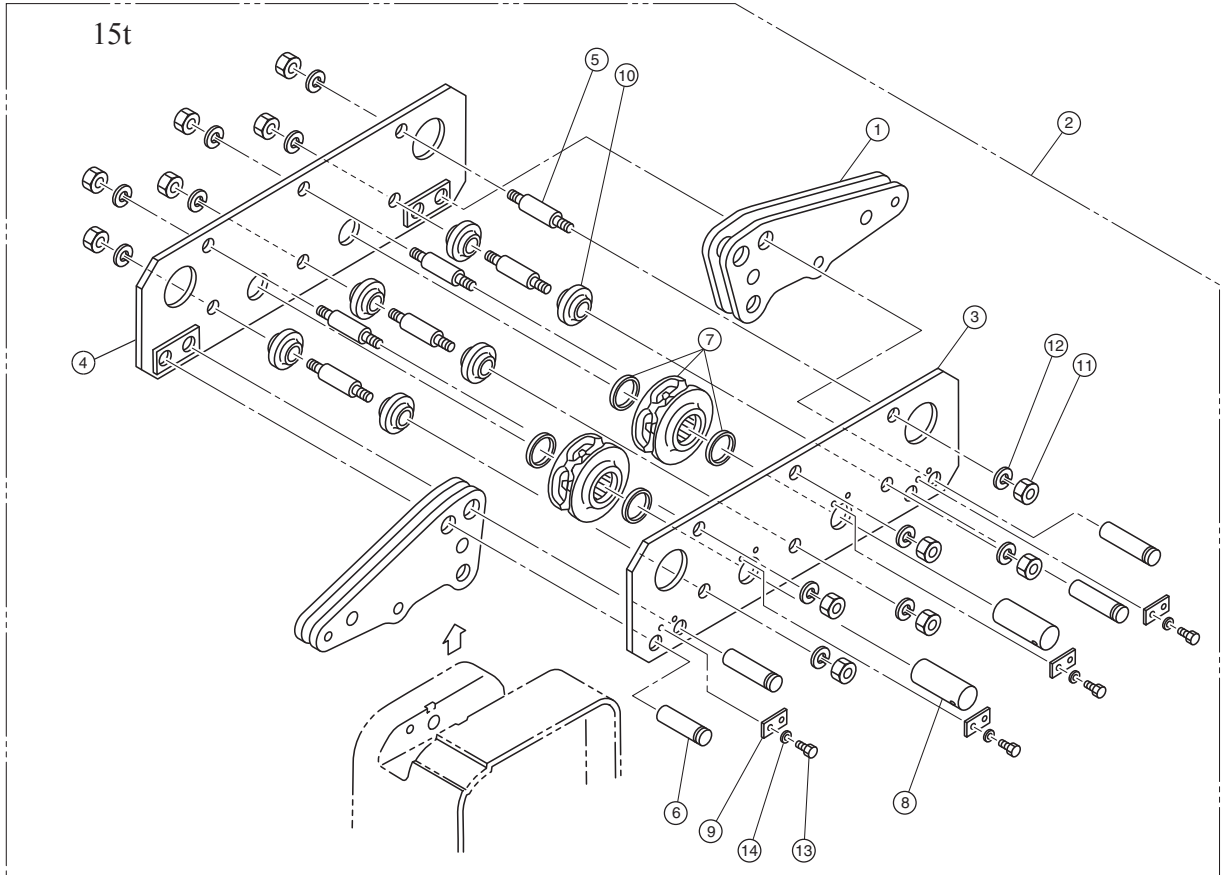

Top Suspension Plate Parts - Plate Suspension Type

ER2-150S/ER2-200S

Figure No.	Part Number	Part Name	150S		200S		Note
			Part Number	Quantity	Part Number	Quantity	
1	5005	Connection yoke assembly	ER2IS5005	2	ER2IS5005	2	
2	1003	Top suspension plate assembly	ER2JS1003	1	ER2KS1003	1	
3	5003	Top suspension plate A assembly	ER2JS5003	1	ER2KS5003	1	
4	5004	Top suspension plate B assembly	ER2JS5004	1	ER2KS5004	1	
5	007	Top stay bolt	E7SE075S9007	6	←	7	
6	008	Suspension shaft	E6SE075S9008	4	←	4	
7	5051	Top idle sheave assembly	ER2HS5051	2	←	3	
8	053	Top shaft	E6SE075S9053	2	←	3	
9	056	Shaft stopper A	ER1HS9056	4	←	5	
10	062	Guide roller	E6SE075S9062	6	←	8	
11	081	Nut	J1NA001-30200	12	←	14	For top stay bolt
12	082	Spring washer	J1WS011-20200	12	←	14	For top stay bolt
13	083	Socket bolt	J1BE1-0801616	8	←	10	For shaft stopper A
14	084	Spring washer	J1WS011-20080	8	←	10	For shaft stopper A

Control Station and Cable (Hook Type)

ER2-100S/ER2-150S/ER2-200S

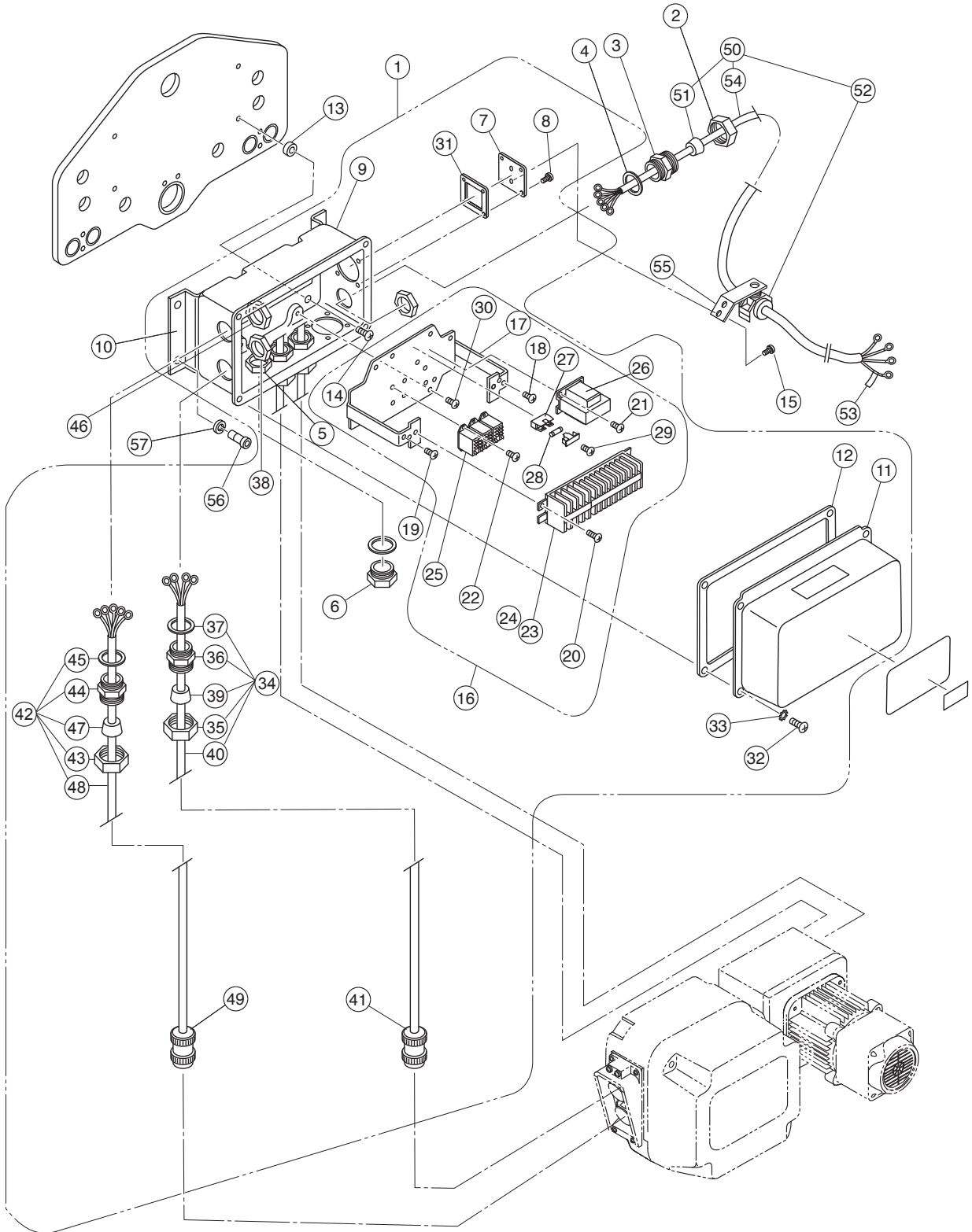

Control Station and Cable (Hook Type)

ER2-100S/ER2-150S/ER2-200S

Figure No.	Part Number	Part Name		100S	150S, 200S	Note
1	1401	Connection box complete set	1			
2	341	Holder A	1	ECP5924AA	←	
3	342	Holder B	1	ECP5924AB	←	
4	343	Packing	2	ECP5924AC	←	
5	344	Holder nut	2	ECP5924AD	←	
6	345	Holder cap	1	ECP5924AE	←	
7	347	Cord cover	1	ER1IS9347	←	
8	348	Machine screw with spring washer	4	J1AP2-5001010	←	For Cord cover
9	401	Connection box	1	MR1IS9401	←	
10	405	Connection box holder	1	MR1HS9405	←	
11	411	Connection box cover	1	MR1DS9411	←	
12	421	Connection box packing	1	MR1DS9421	←	
13	423	Spacer	4	M6SE010S9517	←	
14	424	Machine screw with spring washer	4	J1AP2-8001414	←	For Connection box holder
15	432	Machine screw with spring washer	2	J1AP2-6001010	←	
16	1445	Plate complete set	1			
17	5445	Plate assembly	1	MR2IS5445	←	
18	450	Machine screw with spring washer	1	J1AP2-5000808	←	
19	451	Machine screw with spring washer	3	J1AP2-4000808	←	For ground
20	452	Machine screw with spring washer	2	J1AP2-5001010	←	For Terminal
21	455	Machine screw with spring washer	2	J1AP2-4000808	←	For Transformer
22	461	Machine screw with spring washer	6	J1AW2-3000808	←	For Relay
23	853	Terminal 16P	1	ECP1610AA	←	
24	863	Lead wire	1set			
25	876	Relay	3	MGC42C26A	←	
26	881	Transformer	1	TRF32K611	←	
27	891	Fuse holder	1	ECP92FZAA	←	
28	892	Fuse	1	ECP91FZ01	←	
29	894	Machine screw with spring washer	1	J1AP2-3000808	←	For Fuse holder
30	454	Machine screw with spring washer	4	J1AP2-5001010	←	For Plate assembly
31	818	Cord cover packing	1	M7SE010S9527	←	
32	422	Machine screw with spring washer	4	J1AP2-5001010	←	For connection box cover
33	425	Toothed lock washer	4	J1WH012-10050	←	For Connection box cover
34	1751	Relay cable 4C assembly	2			For Power supply
35	341	Holder A	2	ECP5924AA	←	
36	342	Holder B	2	ECP5924AB	←	
37	343	Packing	2	ECP5924AC	←	
38	344	Holder nut	2	ECP5924AD	←	
39	351	Cable packing	2	ECP6916AA	←	
40	751	Relay cable 4C	2			
41	752	Plug 4P	2	ECP2304AF	←	
42	1761	Relay cable 4C assembly	2			For operation
43	341	Holder A	2	ECP5924AA	←	
44	342	Holder B	2	ECP5924AB	←	
45	343	Packing	2	ECP5924AC	←	
46	344	Holder nut	2	ECP5924AD	←	
47	351	Cable packing	2	ECP6916AA	←	
48	761	Relay cable 4C	2			
49	752	Plug 4P	2	ECP2108AC	←	
50	1771	Power supply cable 4C assembly	2	ZBZC12BH2000	←	

Figure No.	Part Number	Part Name		100S	150S, 200S	Note
51	351	Cable packing	2	ECP6918AA	←	
52	1724	Cable support 19 assembly	2	ECP5900CA	←	
53	741	Name plate G	2	E6LE010S9806	←	
54	771	Power supply cable 4C	1			
55	431	Cable support arm	1	ER11S9431	←	
56	406	Socket bolt	4	J1BE1-0802020	←	For connection box holder
57	407	Spring lock washer	4	J1WS011-20080	←	For connection box holder

Top Hook (Hook Type)

ER2-100S

10t (S)

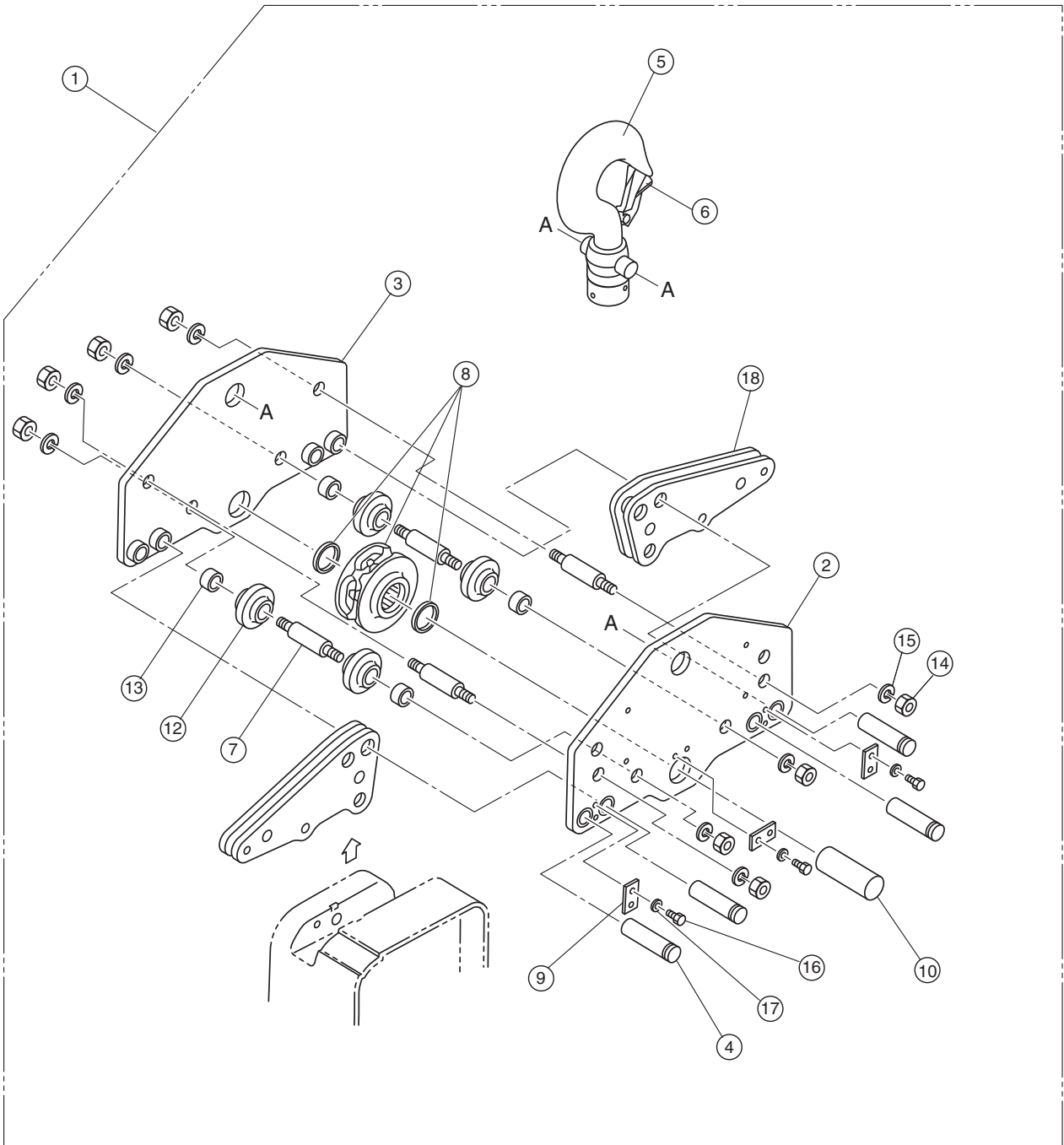

15t

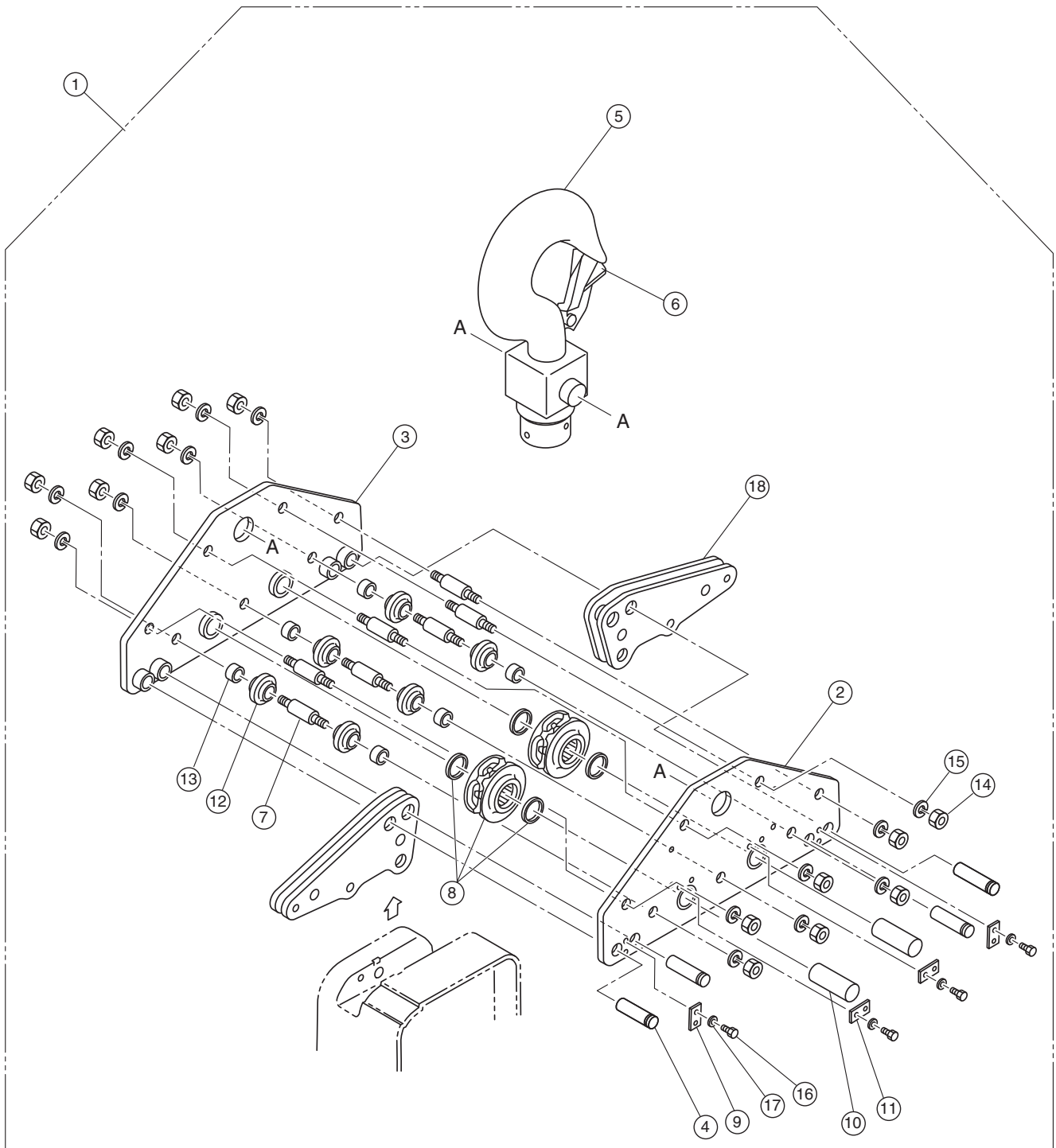

20t

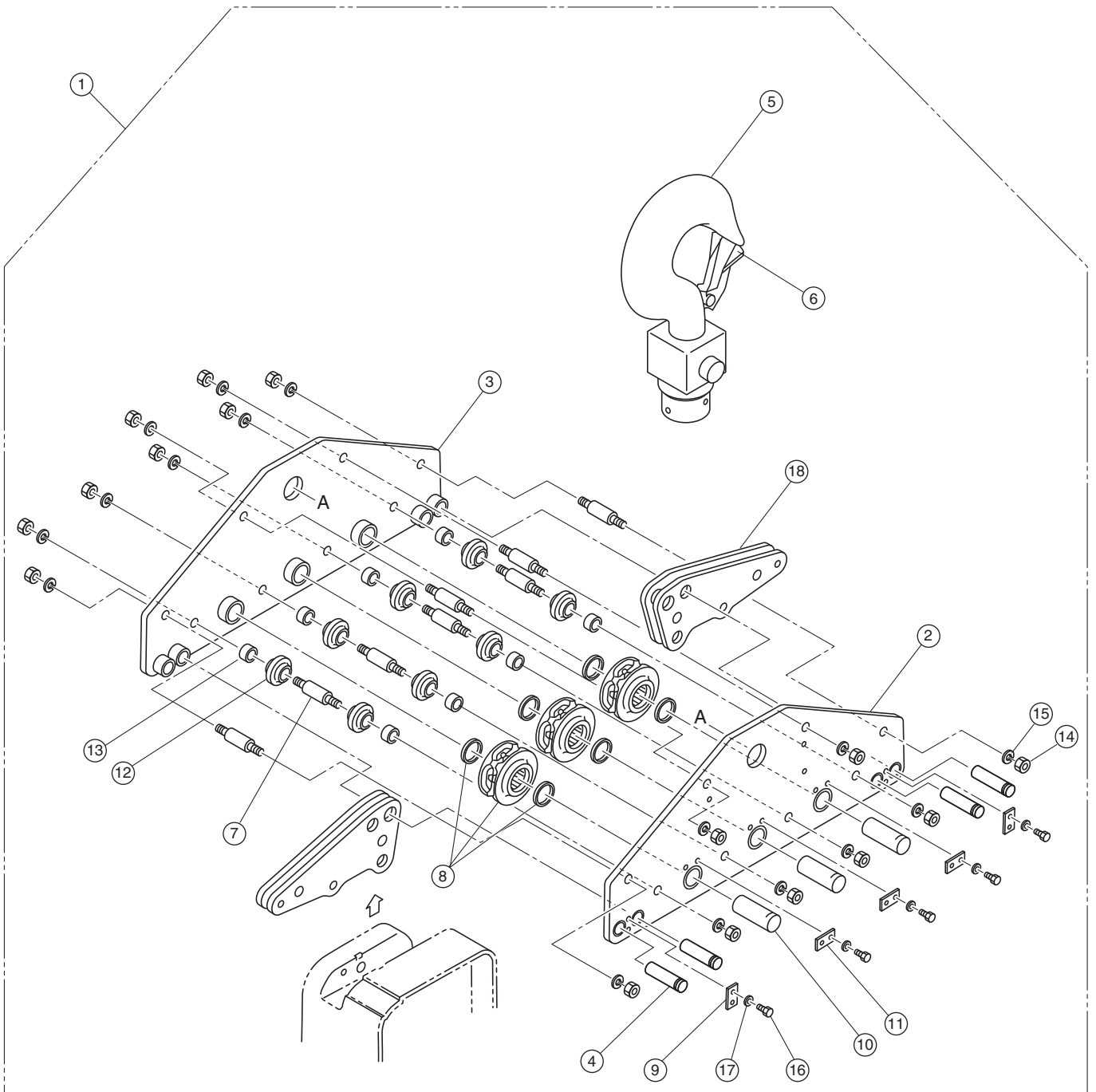

ER2-100S/ER2-150S/ER2-200S

Figure No.	Part Number	Part Name	100S		150S		200S		Note
1	1011	Top hook complete set	ER2IS1011	1	ER2JS1011	1	ER2KS1011	1	
2	5011	Top suspension plate A assembly	ER2IS5011	1	ER2JS5011	1	ER2KS5011	1	
3	5012	Top suspension plate B assembly	ER2IS5012	1	ER2JS5012	1	ER2KS5012	1	
4	013	Suspender shaft B	E6SE100S9013	4	E6SE150S9013	4	←	4	
5	2121	Bottom hook assembly	ER2IS2121	1	ER2JS2121	1	ER2KS2121	1	
6	071	Lever assembly	C2BA150-1071	1	C2BA200-1071	1	C2BA300-1071	1	
7	038	Bottom stay bolt	E7SE075S9038	4	E7SE150S9038	7	←	8	
8	5052	Bottom idle sheave assembly	ER2HS5052	1	←	2	←	3	
9	056	Shaft stopper A	ER1IS9056	3	←	2	←	2	
10	057	Top shaft B	E6SE100S9057	1	E6SE150S9057	2	←	3	
11	060	Shaft stopper B	X		ER1JS9060	2	←	3	
12	062	Guide roller	E6SE075S9062	4	←	6	←	8	
13	065	Bottom collar	E6SE075S9065	4	E6SE150S9065	6	←	8	
14	081	Nut	J1NA001-30200	8	←	14	←	16	
15	082	Spring washer	J1WS011-20200	8	←	14	←	16	
16	083	Socket bolt	J1BE1-0801616	6	←	8	←	10	For shaft stopper A, B
17	084	Spring washer	J1WS011-20080	6	←	8	←	10	For shaft stopper A, B
18	5005	Connection yoke assembly	ER2IS5005	2	←	2	←	2	

MR2-075L/100L with ER2-100L/100L with ER2-100S/150L/200L

Motor related

Figure No.	Part Number	Part Name		075L, 100L with ER2-100L, 100L with ER2-100S		150, 200L	Note
1	1321	Motor complete set	1		2		
2	248	Gear frame packing	1	MR1IS9248	2	←	
3	249	Set pin	2	MR1DS9249	4	←	For gear frame and frame G
4	250	Bolt	4	J1BA1-0802525	8	←	For gear frame. Integrated type with spring/flat washer is available. (251 and 252 are not necessary.)
5	251	Spring lock washer	4	J1WS011-20080	8	←	For gear frame
6	252	Washer	4	J1WA011-00080	8	←	For gear frame
7	253	Ball bearing	1	J1GR060-06204	2	←	For gear frame on motor side
8	5261	Brake drum assembly	1	MR1DS5261	2	←	
9	264	Brake spring	1	M3ES010-9304	2	←	
10	265	Bumper	1	MR1DS9265	2	←	
11	281	Guard	1	MR1DS9281	2	←	
12	5921	Motor shaft with rotor	1	MR1DS5291	2	←	
13	293	Oil seal	1	MR1DS9293	2	←	
14	1301	Motor cover assembly	1	MR1DS1301	2	←	
15	304	Socket bolt	4	J1BE1-0802222	8	←	For motor cover
16	5321	Motor frame with stator	1		2		
17	324	Terminal cover	1	M6FE005S9206	2	←	
18	325	Terminal cover packing	1	MR1DS9325	2	←	
19	326	Coil cover	1	MR1DS9326	2	←	
20	331	Machine screw with spring washer	4	J1AP2-5001010	8	←	For terminal cover
21	332	Machine screw with spring washer	2	J1AW2-4002020	4	←	For terminal plate
22	334	Machine screw with spring washer	1	J1AP2-4000808	2	←	For ground
23	851	Terminal 6P	1	M6FE005S9516	2	←	

Gear related

Figure No.	Part Number	Part Name		075L, 100L with ER2-100L, 100L with ER2-100S		150, 200L	Note
24	241	Gear #2	1	MR1IS9241	2	←	
25	5242	Gear #3 assembly	1	MR1IS5242	2	←	
26	242	Gear #3	1	MR1IS9242	2	←	
27	245	Ball bearing	2	J1GR020-06205	4	←	For gear #3 on frame G side, with snap ring
28	257	Bearing holder	1	MR1IS9257	2	←	
29	258	Snap ring	1	J1SS000-00052	2	←	
30	244	Spacer	1	MR1IS9244	2	←	
31	246	Snap ring	1	J1SS000-00025	2	←	For gear 3
32	259	Socket bolt	4	J1BE1-0603030	8	←	
33	260	Spring lock washer	4	J1WS011-20060	8	←	

Frame and Weel / Suspension shaft related

MR2-075L/100L with ER2-100L/100L with ER2-100S/150L/200L

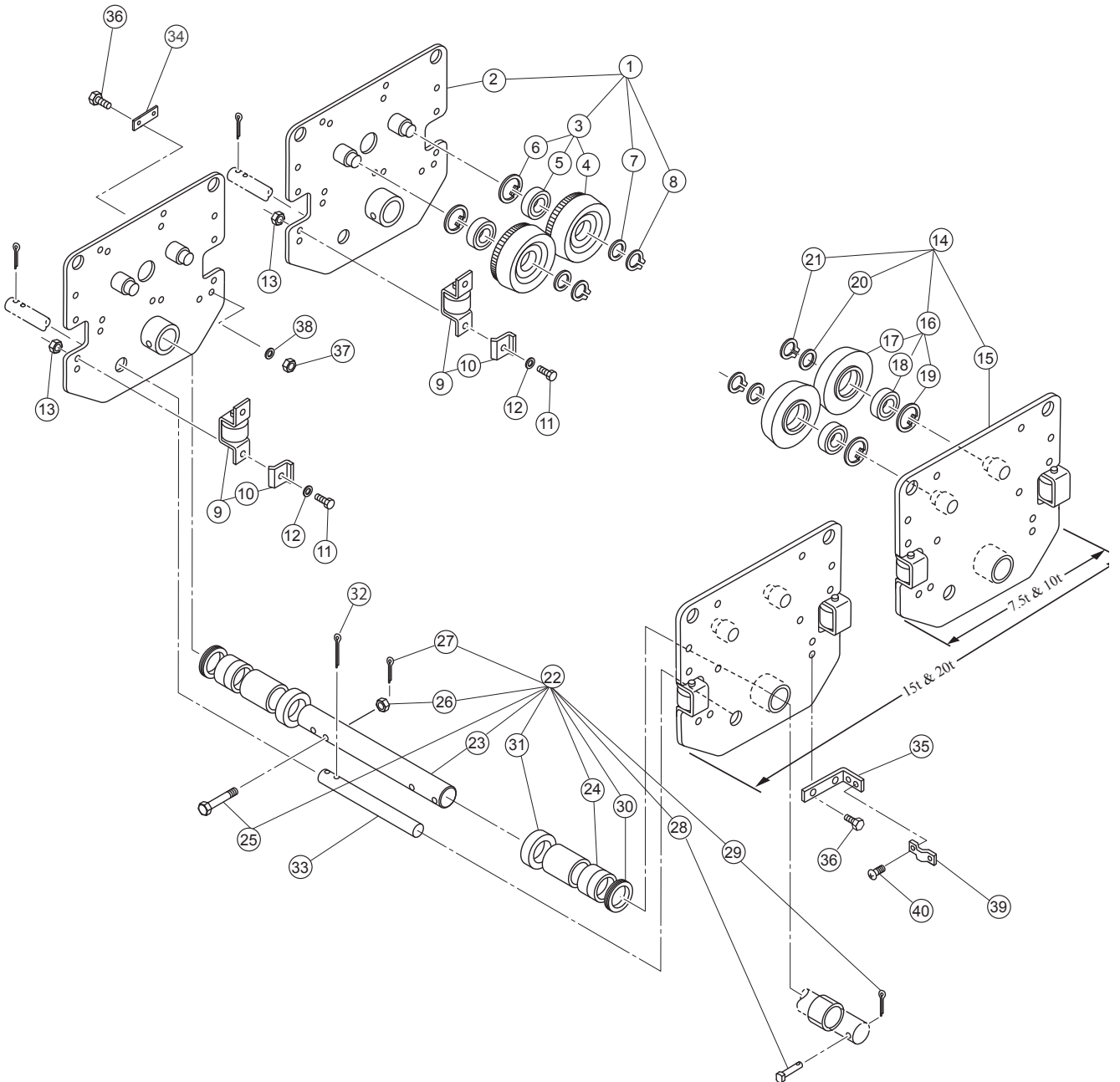

MR2-075L/100L with ER2-100L/100L with ER2-100S/150L/200L

Frame and Wheel related

Figure No.	Part Number	Part Name		075L, 100L with ER2-100L, 100L with ER2-100S		150, 200L	Note
1	1201	Side plate G complete set	1		2		
	2201						
2	5201	Side plate G assembly	1	MR1IS5201	2	←	
3	1231	Track wheel G assembly	2	M6SE100S1101	4	←	For I beam
	1237	Track wheel GF assembly	2	M6SE100S1105	4	←	For wide beam and H beam
4	231	Track wheel G	2	M6SE100S9101	4	←	For I beam
	237	Track wheel GF	2	M6SE100S9105	4	←	For wide beam and H beam
5	233	Ball bearing	2	J1GR020-06309	4	←	
6	234	Snap ring	2	J1SR000-00100	4	←	
7	235	Washer	2	M6SE100S9104	4	←	For track wheel G and GF
8	236	Snap ring	2	J1SS000-00045	4	←	For track wheel G and GF
9	1211	Side roller complete set	2	MR1GS1211	4	←	
10	218	Stopper plate	2	M6SE050S9144	4	←	
11	219	Bolt	4	J1BA1-1604545	8	←	For side roller holder
12	220	Spring lock washer	4	J1WS011-20160	8	←	For side roller holder
13	221	Nut	4	J1NA001-30160	8	←	For side roller holder
14	1202	Side plate S complete set	1		2		
	2202						
15	5202	Side plate S assembly	1	MR1IS5202	2	←	
16	1232	Track wheel S assembly	2	M6SE100S1102	4	←	For I beam
	1238	Track wheel SF assembly	2	M6SE100S1106	4	←	For wide beam and H beam
17	232	Track wheel S	2	M6SE100S9102	4	←	For I beam
	232	Track wheel SF	2	M6SE100S9106	4	←	For wide beam and H beam
18	233	Ball bearing	2	J1GR020-06309	4	←	
19	234	Snap ring	2	J1SR000-00100	4	←	
20	235	Washer	2	M6SE100S9104	4	←	For track wheel S and SF
21	236	Snap ring	2	J1SS000-00045	4	←	For track wheel S and SF
9	1211	Side roller complete set	2	MR1GS1211	4	←	
10	218	Stopper plate	2	M6SE050S9144	4	←	
11	219	Bolt	4	J1BA1-1604545	8	←	For side roller holder
12	220	Spring lock washer	4	J1WS011-20160	8	←	For side roller holder
13	221	Nut	4	J1NA001-30160	8	←	For side roller holder

Suspension shaft related

Figure No.	Part Number	Part Name		075L, 100L with ER2-100L, 100L with ER2-100S		150, 200L	Note
22	1115	Suspension shaft complete set (220)	1	M6SS100S1115	2	←	For beam width 150-220
23	115	Suspension shaft (220)	1	M6SE100S9115	2	←	
24	117	Collar B	6	M6SE100S9117	12	←	
25	161	Bolt	1	M6SE100S9161	2	←	
26	162	Slotted nut	1	J1NL002-20160	2	←	
27	163	Split pin	1	J1PW01-040030	2	←	
28	164	Shaft stopper	1	M6SE100S9164	2	←	
29	165	Split pin	1	J1PW02-040028	2	←	
30	118	Thin spacer	8	M6SE100S9116	16	←	
22	1181	Suspension shaft complete set (300)	1	M6SS100S1181	2	←	For beam width 221-305
23	181	Suspension shaft (300)	1	M6SE100S9181	2	←	
24	117	Collar B	7	M6SE100S9117	14	←	
25	161	Bolt	1	M6SE100S9161	2	←	
26	162	Slotted nut	1	J1NL002-20160	2	←	
27	163	Split pin	1	J1PW01-040030	2	←	
28	164	Shaft stopper	1	M6SE100S9164	2	←	
29	165	Split pin	1	J1PW02-040028	2	←	
30	118	Thin spacer	8	M6SE100S9116	16	←	
31	182	Fixing collar (300)	2	M6SE100S9182	4	←	
32	089	Split pin	2	J1PW01-050050		X	
33	010	Fixing shaft	1	E6SE075S9010		X	For standard beam
	018	Fixing shaft (300)	1	E7SE075S9019		X	For wide beam
34	224	Connection plate		X	1	M6SE200S9105	
35	225	Connection plate S		X	1	MR1JS9225	
36	226	Bolt		X	4	M6SE200S9106	
37	227	Nut		X	4	J1NA002-10120	
38	228	Spring lock washer		X	4	J1WS012-20120	
39	816	Cord chain stopper		X	1	E6LE010S9614	
40	817	Machine screw with spring washer		X	2	J1AP2-6000808	

Push Button

MR2-075L/100L with ER2-100L/100L with ER2-100S/150L/200L

7.5t, 10t(L)

10t(S), 15t, 20t

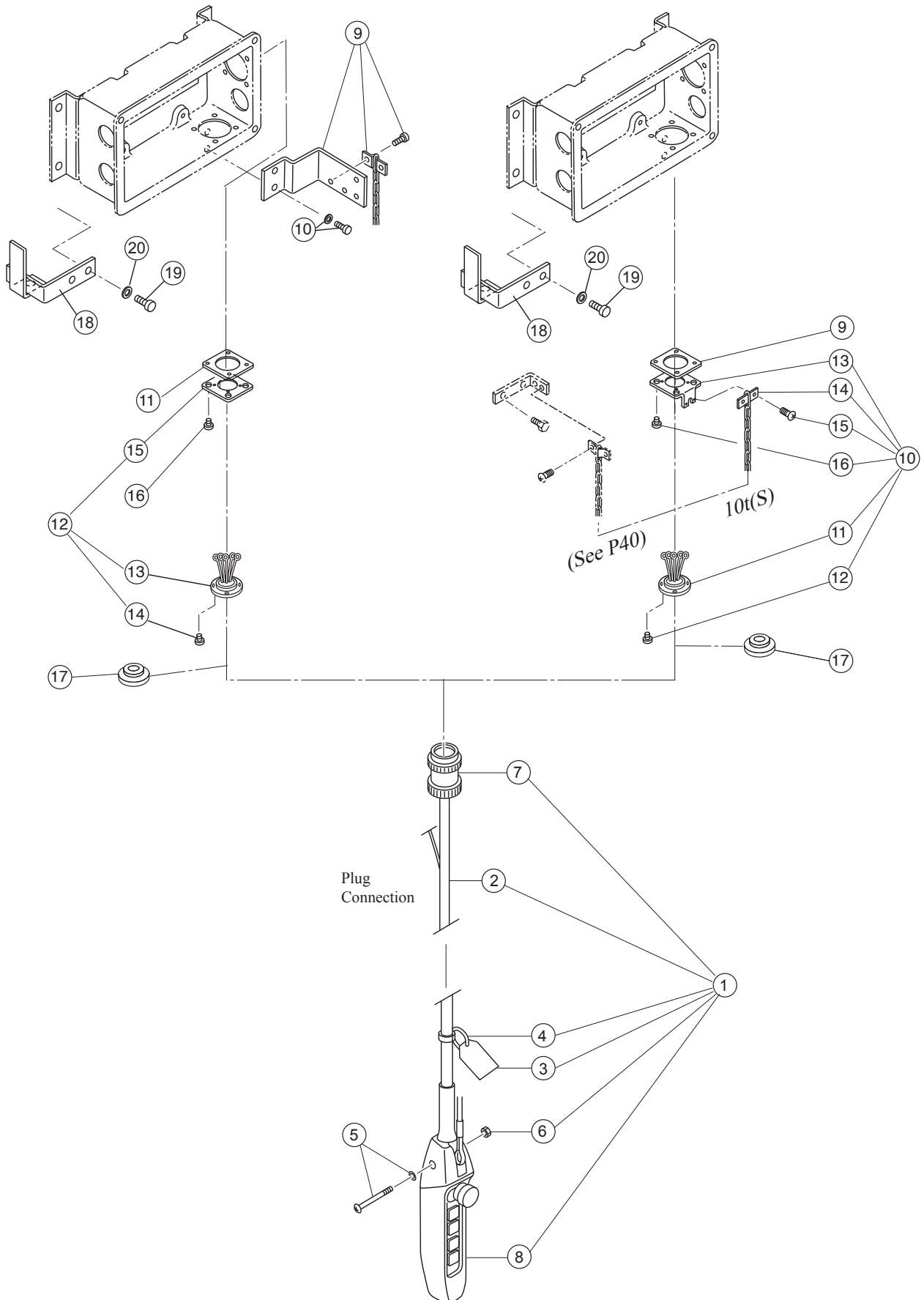

MR2-075L/100L with ER2-100L/100L with ER2-100S/150L/200L

7.5t, 10t(L)

Figure No.	Part Number		Part Name	075L, 100L with ER2- 100L	Note
1	1781	1	Push button cord 6C assembly		
2	781	1	Push button cord 6C		
3	783	1	Warning tag PB	SWD9013AE	
4	784	1	Tag holder	E7SE003S9787	
5	788	1	Machine screw with spring washer	J1AP2-4002608	
6	789	1	Nut	J1NA004-10040	
7	792	1	Plug 8P		
8	1801	1	5 push button switch assembly		
9	1481	1	Bar holder assembly	MR1DS1481	For Cable support bar
10	482	2	Socket bolt	J1BG1-1002828	
11	818	1	Cord cover packing	M7SE010S9527	
12	1811	1	Socket 8P complete set		
13	5811	1	Socket 8P assembly		
14	814	4	Tapping flat head machine screw	J1AL2-4001212	
15	346	1	Plate P	ECP5924AH	
16	820	4	Machine screw with spring washer	J1AP2-5001010	
17	819	1	Socket cover 4P		
18	511	1	Cable hanger pusher	T2AQ100-9101	
19	516	2	Bolt	J1BA1-1003026	
20	517	2	Spring lock washer	J1WS011-20100	

10t(S), 15t, 20t

Figure No.	Part Number		Part Name	100L with ER2-100S	150L, 200L	Note
1	1781	1	Push button cord 6C assembly			
2	781	1	Push button cord 6C			
3	783	1	Warning tag PB	SWD9013AE	←	
4	784	1	Tag holder	E7SE003S9787	←	
5	788	1	Machine screw with spring washer	J1AP2-4002608	←	
6	789	1	Nut	J1NA004-10040	←	
7	792	1	Plug 8P			
8	1801	1	5 push button switch assembly			
9	818	1	Cord cover packing	M7SE010S9527	←	
10	1811	1	Socket 8P complete set			
11	5811	1	Socket 8P assembly			
12	814	4	Tapping flat head machine screw	J1AL2-4001212	←	
13	815	1	Socket holder	M6ME010S9529	←	
14	816	1	Cord chain stopper	M6FE005S9530	←	
15	817	2	Machine screw with spring washer	J1AP2-5001010	←	
16	820	4	Machine screw with spring washer	J1AP2-5001010	←	
17	819	1	Socket cover 4P			
18	511	1	Cable hanger pusher	T2AQ100-9101	←	
19	516	2	Bolt	J1BA1-1003026	←	
20	517	2	Spring lock washer	J1WS011-20100	←	

Control Station and Cable - Plate Suspension Type(7.5t, 10t(L))

MR2-075L/100L with ER2-100L

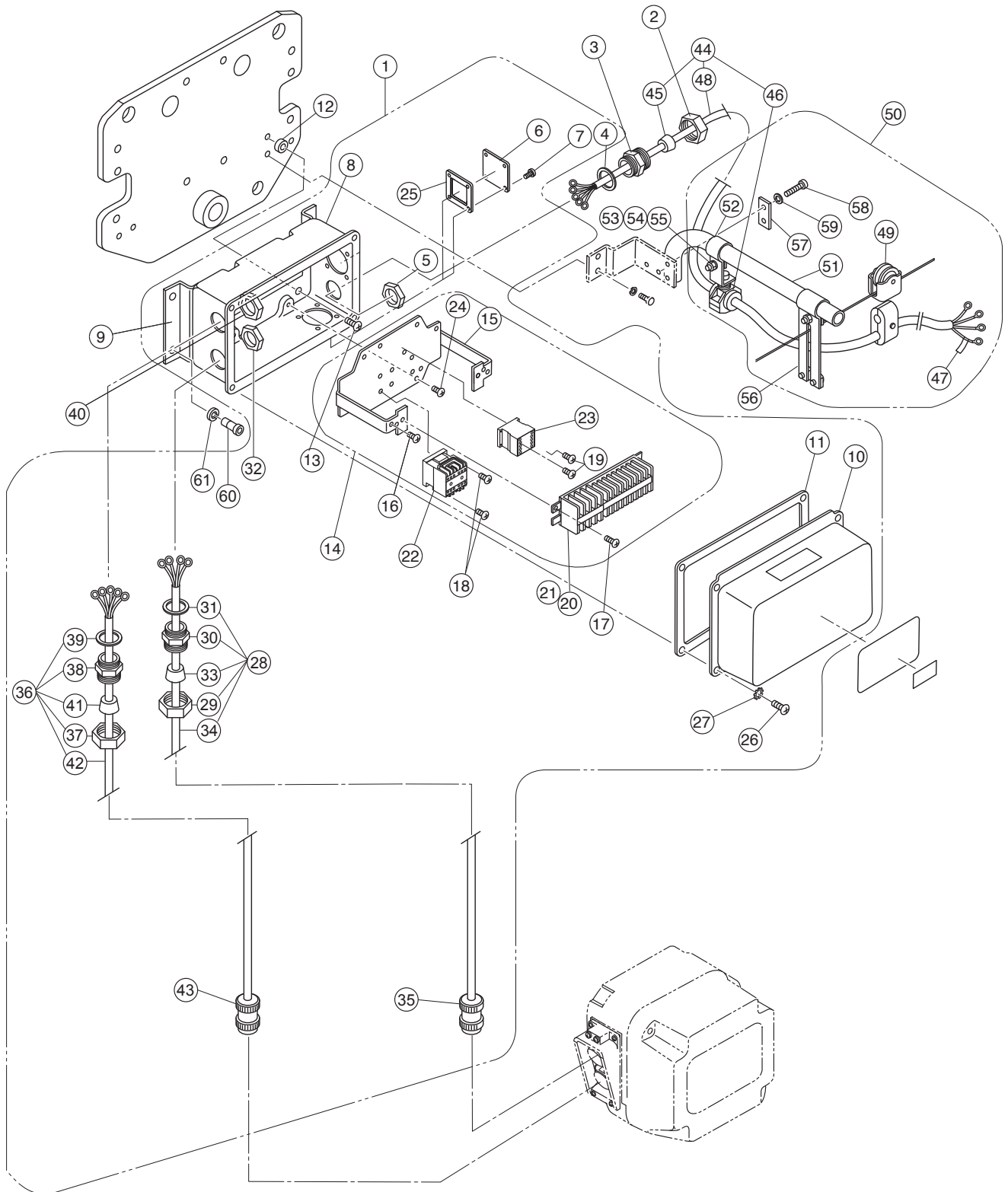

Control Station and Cable - Plate Suspension Type(7.5t, 10t(L))

MR2-075L/100L with ER2-100L

Suspension type

Figure No.	Part Number	Part Name		075L, 100L with ER2-100L	Note
1	1401	Connection box complete set	1		
2	341	Holder A	1	ECP5924AA	
3	342	Holder B	1	ECP5924AB	
4	343	Packing	1	ECP5924AC	
5	344	Holder nut	1	ECP5924AD	
6	347	Cord cover	1	E6LE010S9630	
7	348	Machine screw with spring washer	4	J1AP2-5001010	
8	401	Connection box	1	MR1DS9401	
9	405	Connection box holder	1	MR1HS9405	
10	411	Connection box cover	1	MR1DS9411	
11	421	Connection box packing	1	MR1DS9421	
12	423	Spacer	4	M6SE010S9517	
13	424	Machine screw with spring washer	4	J1AP2-8001414	For Connection box holder
14	1445	Plate complete set	1		
15	5445	Plate assembly		MR2DS5445	
16	451	Machine screw with spring washer	3	J1AP2-4000808	For ground
17	452	Machine screw with spring washer	2	J1AW2-4001212	For Terminal
18	453	Machine screw with spring washer	2	J1AP2-4001616	For Contactor
19	457	Machine screw with spring washer	2	J1AP2-4001212	For Contactor
20	853	Terminal 16P	1	ECP1416AA	
21	863	Lead wire	1set		
22	871	Contacto	1	MGC22306B	
23	873	Contacto	1	MGC12306B	
24	454	Machine screw with spring washer	4	J1AP2-5001010	For Plate assembly
25	818	Cord cover packing	1		
26	422	Machine screw with spring washer	4	J1AP2-5001010	For Connection box cover
27	425	Toothed lock washer	4	J1WH012-10050	For Connection box cover
28	1751	Relay cable 4C assembly	1	MR2HS1759	For Power supply
29	341	Holder A	1	ECP5924AA	
30	342	Holder B	1	ECP5924AB	
31	343	Packing	1	ECP5924AC	
32	344	Holder nut	1	ECP5924AD	
33	351	Cable packing	1	ECP6916AA	
34	751	Relay cable 4C	1		
35	752	Plug 4P	1	ECP2304AF	
36	1761	Relay cable 4/6C assembly	1	MR2HS1768	For operation
37	341	Holder A	1	ECP5924AA	
38	342	Holder B	1	ECP5924AB	
39	343	Packing	1	ECP5924AC	
40	344	Holder nut	1	ECP5924AD	
41	351	Cable packing	1	ECP6916AA	
42	761	Relay cable 4/6C	1		
43	762	Plug 8P	1	ECP2108AC	
44	1771	Power supply cable 4C assembly	1		
45	351	Cable packing	1	ECP6916AA	
46	1724	Cable support 16/19 assembly	1	M3ES010-1724	
47	741	Name plate G	1	E6LE010S9806	
48	771	Power supply cable 4C	1		
49	1641	Cable hanger 17 assembly	n		
		Cable hanger 15 assembly	n		
50	1491	Cable support bar complete set	1	MR1DS1491	

Figure No.	Part Number	Part Name		075L, 100L with ER2-100L	Note
51	491	Cable support bar	1	MR1DS949	
52	492	Cable support arm	1	MR1DS949	
53	497	Bolt	2	J1BA2-0802525	
54	498	Spring lock washer	2	J1WS012-20080	
55	499	Nut	2	J1NA002-20080	
56	1493	Wire guide assembly	1	MR1DS149	
57	501	Support bar holder (plate)	1	MR1DS950	
58	505	Bolt	2	J1BA2-0803030	
59	506	Spring lock washer	2	J1WS012-20080	
60	406	Socket bolt	4	J1BE1-0802020	For Connection box holder
61	407	Spring lock washer	4	J1WS011-20080	For Connection box holder

Control Station and Cable - Plate Suspension Type(10t(S), 15t, 20t)

MR2-100L with ER2-100S/MR2-150L/200L

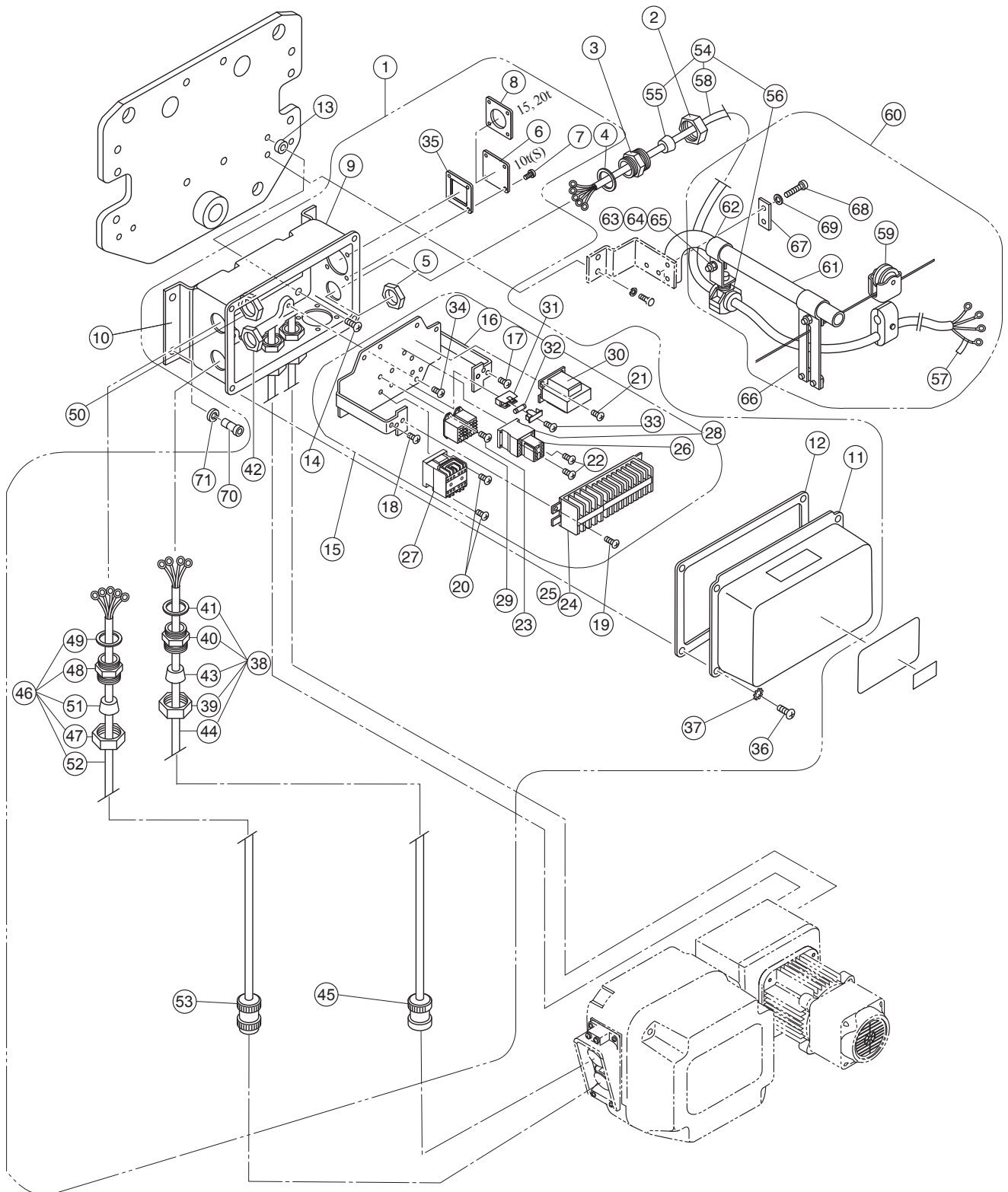

Control Station and Cable - Plate Suspension Type(10t(S), 15t, 20t)

MR2-100L with ER2-100S/MR2-150L/200L

Suspension type

Figure No.	Part Number	Part Name		100L with ER2-100S		150, 200L	Note
1	1401	Connection box complete set	1		1		
2	341	Holder A	1	ECP5924AA	1	←	
3	342	Holder B	1	ECP5924AB	1	←	
4	343	Packing	1	ECP5924AC	1	←	
5	344	Holder nut	1	ECP5924AD	1	←	
6	347	Cord cover	1	E6LE010S9630	1	X	
7	348	Machine screw with spring washer	4	J1AP2-5001010	4	←	
8	349	Plate D	1	X	1	ECP5924AF	
9	401	Connection box	1	MR1DS9401	1	←	
10	405	Connection box holder	1	MR1HS9405	1	←	
11	411	Connection box cover	1	MR1DS9411	1	←	
12	421	Connection box packing	1	MR1DS9421	1	←	
13	423	Spacer	4	M6SE010S9517	4	←	
14	424	Machine screw with spring washer	4	J1AP2-8001414	4	←	For Connection box holder
15	1445	Plate complete set	1		1		
16	5445	Plate assembly	1	MR2DS5445	1	MR2IS5445	
17	450	Machine screw with spring washer	1	J1AP2-5000808	1	←	For ground
18	451	Machine screw with spring washer	5	J1AP2-4000808	5	←	For ground
19	452	Machine screw with spring washer	2	J1AP2-5001010	2	←	For Terminal
20	453	Machine screw with spring washer	2	J1AP2-4001616	2	←	For Contactor
21	455	Machine screw with spring washer	2	J1AP2-4000808	2	←	For Transformer
22	457	Machine screw with spring washer	2	J1AP2-4001212	2	←	For Contactor
23	461	Machine screw with spring washer	4	J1AW2-3000808	4	←	For Relay
24	853	Terminal 10P	1	ECP1610AA	1	←	
25	863	Lead wire	1set		1set		
26	870	Auxiliary contactor	1	MGC92409A	1	←	
27	871	Contactor	1	MGC23306C	1	←	
28	873	Contactor	1	MGC12306B	1	←	
29	876	Relay	2	MGC42C26A	2	←	
30	881	Transformer	1		1		
31	891	Fuse holder	1	ECP92FZAA	1	←	
32	892	Fuse	1	ECP91FZ01	1	←	
33	894	Machine screw with spring washer	1	J1AP2-3000808	1	←	For Fuse holder
34	454	Machine screw with spring washer	4	J1AP2-5001010	4	←	For Plate assembly
35	818	Cord cover packing	1		1		
36	422	Machine screw with spring washer	4	J1AP2-5001010	4	←	For Connection box cover
37	425	Toothed lock washer	4	J1WH012-10050	4	←	For Connection box cover
38	1751	Relay cable 4C assembly	2	MR2IS1759	2	MR2JS1759	For Power supply
39	341	Holder A	2	ECP5924AA	2	←	
40	342	Holder B	2	ECP5924AB	2	←	
41	343	Packing	2	ECP5924AC	2	←	
42	344	Holder nut	2	ECP5924AD	2	←	
43	351	Cable packing	2	ECP6916AA	2	←	
44	751	Relay cable 4C	2		2		
45	752	Plug 4P	2	ECP2304AF	2	←	
46	1761	Relay cable 4/6C assembly	2	MR2IS1768	2	MR2JS1768	For operation
47	341	Holder A	2	ECP5924AA	2	←	
48	342	Holder B	2	ECP5924AB	2	←	
49	343	Packing	2	ECP5924AC	2	←	
50	344	Holder nut	2	ECP5924AD	2	←	

Figure No.	Part Number	Part Name		100L with ER2-100S		150, 200L	Note
51	351	Cable packing	2	ECP6916AA	2	←	
52	761	Relay cable 4/6C	2		2		
53	762	Plug 8P	2	ECP2108AC	2	←	
54	1771	Power supply cable 4C assembly	1		1	←	
55	351	Cable packing	1	ECP6918AA	1	←	
56	1742	Cable support 16/19 assembly	1	ECP5900CA	1	←	
57	741	Name plate G	1	E6LE010S9806	1	←	
58	771	Power supply cable 4C	1		1		
59	1641	Cable hanger 17 assembly	n		n		
		Cable hanger 15 assembly	n	X	n		
60	1491	Cable support bar complete set	1	MR1DS1491	2	←	
61	491	Cable support bar	1	MR1DS949	1	←	
62	492	Cable support arm	1	MR1DS949	1	←	
63	497	Bolt	2	J1BA2-0802525	2	←	
64	498	Spring lock washer	2	J1WS012-20080	2	←	
65	499	Nut	2	J1NA002-20080	2	←	
66	1493	Wire guide assembly	1	MR1DS149	1	←	
67	501	Support bar holder (plate)	1	MR1DS950	1	←	
68	505	Bolt	2	J1BA2-0803030	2	←	
69	506	Spring lock washer	2	J1WS012-20080	2	←	
70	406	Socket bolt	4	J1WS011-20080	4	←	For Connection box holder
71	407	Spring lock washer	4	J1BE1-0802020	4	←	For Connection box holder

Hanger Plate (Executive for 7.5t)

MR2-075L

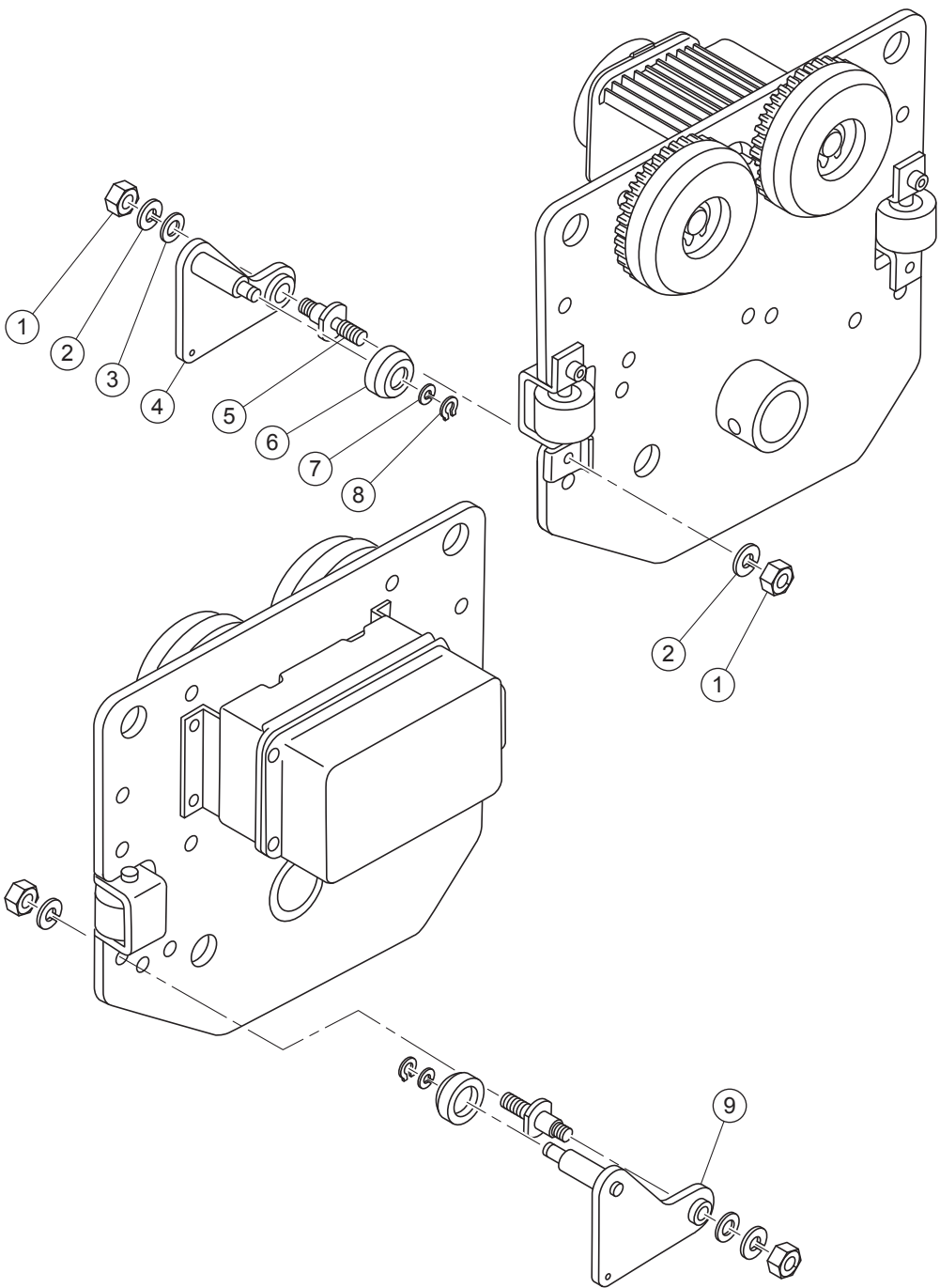

Exclusive parts for 7.5t

Figure No.	Part Number	Part Name		075L	Note
1	411	Nut	4	J1NA001-30160	For bolt
2	413	Spring washer	4	J1WS011-20160	For bolt
3	412	Washer	2	J1WB011-10160	For bolt
4	5401	Hanger plate A assembly	1	M6SE075S1401	
5	408	Bolt	2	M6SE075S9408	
6	1405	Hanger wheel assembly	2	M6SE075S1405	
7	407	Wheel washer	2	T6GA010-9104	
8	415	Snap ring	2	J1SS000-00015	For hanger wheel assembly
9	5402	Hanger plate B assembly	1	M6SE075S5402	

KITO

URL. <http://www.kito.co.jp>