

KITO Overload Limiter (YL2 Series) ***(125 kg to 5 t)***

Operation Manual

Introduction

The KITO Overload Limiter (YL2) is dedicated equipment in conjunction with the ER2 Series Electric Chain Hoist, which is designed to break the lifting circuit as well as to allow only the lowering (not lifting) while sensing overload conditions.

Safety Precautions

DANGER



Prohibited

- Do not use this overload limiter under overloaded conditions.
- The overload limiter should be assembled / disassembled only by authorized maintenance or competent personnel.

Failure to follow these precautions may cause accidents resulting in serious or even fatal injury.

CAUTION



Compulsory

- This Operation Manual contains the information specific to the KITO Overload Limiter (YL2). Before use, read and comply with the instructions given in this manual and “ER2 Series Electric Chain Hoist Owner’s Manual” (separate document).
- Do not use the overload limiter in conjunction with any other machine than the ER2 Series Electric Chain Hoist.
- Do not use the overload limiter whose capacity does not match with the hoist’s capacity.
- Do not lift an overload to check the function of the overload limiter.

Failure to follow these precautions may cause accidents resulting in serious or even fatal injury.

Overload Limiter Specifications

■ Specifications

- Applicable hoist : ER2 Series Electric Chain Hoist (125 kg to 5 t)
- Power voltage : 3-phase, voltage equivalent to hoist, 50/60 Hz
- Preset : 115% ± 8% of the capacity *
- Adjustable range : 90% to 135% of the capacity; accuracy: ± 8% *
- Enclosure rate : IP55
- Ambient temperature : -20°C to +40°C
- Ambient humidity : 85% RH (no condensation)

*(In dual speed electric chain hoist, the preset value is set as 115% for the high speed lifting. In the low speed lifting, the force will be about 20% higher than the value at high speed.)

■ Type of installation on hoist

Installation varies in capacity or conjunction with the trolleys as shown on the following page. Therefore please check in advance how the overload limiter is installed on your hoist. In order to mount the hoist to a trolley, connect the suspender on the top of the hoist to the trolley.

■ Precautions for use

- In hook suspension, a hook is attached perpendicular from that of the trolley standard installation. For the same hook installation as the standard in direction, connect appropriate fittings (including master links and high cup rings) to the top hook and supporting structure.
- For the limiter on the ER2SG (the geared trolley suspension), the hand chain is located further apart from the hoist body than that of the standard to prevent the body from impeding.

■ **Product type**

● **125 kg to 2.5 t: Single chain fall**

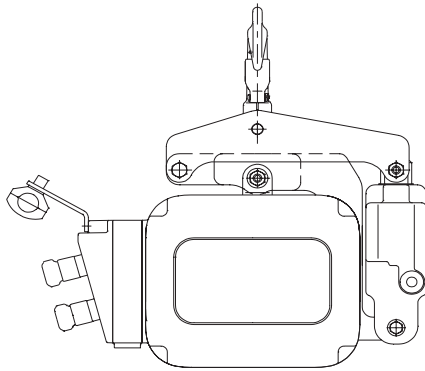

ER2
(Hook suspension)

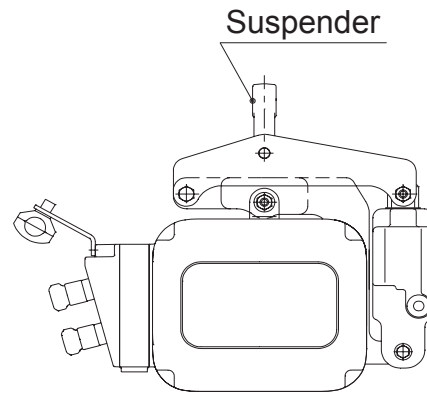

ER2M/ER2SG/ER2SP
(Suspension)

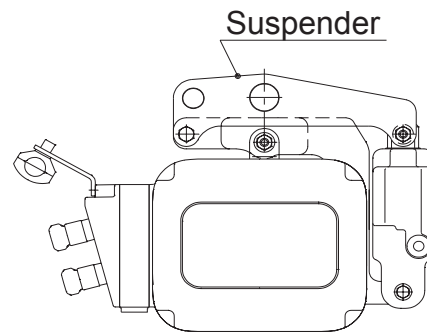

ER2M
(Low head)

● **3 t to 5 t: Double chain fall**

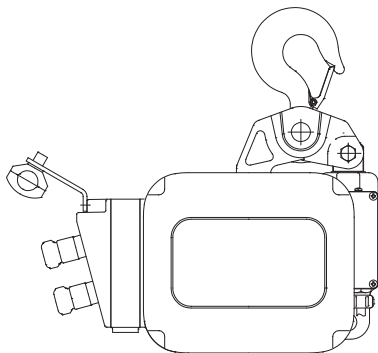

ER2
(Hook suspension)

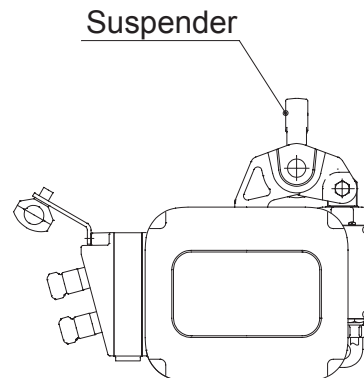

ER2M/ER2SG/ER2SP
(Suspension)

Installation

DANGER



Compulsory

- **Insert always a new split pin and then make sure to bend both its ends.**
Failure to follow these precautions may cause accidents resulting in serious or even fatal injury.

■ Combination with Motorized Trolley MR2

■ Installation of adjusting spacers

The spacer arrangement for a standard suspension with the motorized trolley (low head combination), refers to the following change in the section “Checking the Number of the Assembled Adjusting Spacers and Their Positions” in Chapter 1 of “ER2 Series Electric Chain Hoist Owner’s Manual” (separate document).

- For a hoist capacity of 2 t or less, remove 2 of the thick spacer L (1 at each side plate).
- For a hoist capacity of 2.5 t, remove 2 of the thick spacer L (1 at each side plate), and 2 thick spacers (1 at each side plate).

NOTE: For a hoist capacity of 2.8 t or more or in “suspension” (refer to Page 3) combination, nothing to change in adjusting spacers.

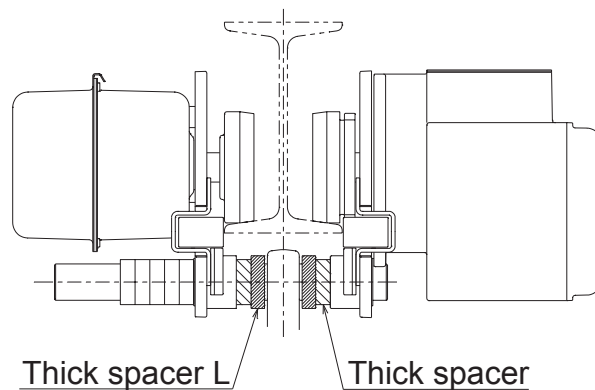

■ Mount to motorized trolley

To mount the motorized trolley, connect securely the suspender to the trolley with reference to the section “Combination with the Trolley” in Chapter 1 of “ER2 Series Electric Chain Hoist Owner’s Manual” (separate document).

■ Combination with Manual Trolley Model TS2 (TSP/TSG)

The spacer arrangement for the manual trolley (TSP/TSG) suspension refers to the section “Combination of the Electric Chain Hoist and the Manual Trolley” in Chapter 1 of “ER2 Series Electric Chain Hoist Owner’s Manual” (separate document) to connect the suspender to the trolley.

Detection of Overload

- The overload limiter is designed to be set to a force applied when the load lifts off but however may be set off under a lighter load than the fixed force while the load is suspended or inched.
- In dual speed electric chain hoist, the force is different between high and low speed lifting. It is set as 115% for the high speed lifting. In the low speed lifting, the force will be 20% higher than the value at high speed.
- The preset force at the factory and practically triggered force may differ depending on the crane installation conditions (girder, end carriage, structure of traveling trestle and so on).
- Make adjustments of the force to lifting speed or installation site, by referring to the section “Setting of the Overload Limiter.”

Setting of the Overload Limiter

⚠ DANGER



Prohibited

- **Do not adjust the set load beyond the adjustment range (90% to 135% of the capacity).**

Failure to follow these precautions may cause accidents resulting in serious or even fatal injury.



Compulsory

- **Make sure to tighten securely the plate screw.**

Failure to follow these precautions may cause accidents resulting in serious or even fatal injury.

■ How to adjust the set load

1) Remove the casing cover of the overload limiter by un-tightening the screws and loosen the plate screw inside the casing.

2) With a load corresponding to the set load lifted, adjust the height of the adjuster to contact the adjuster with the limit switch end.

- To increase the set load, loosen the adjuster to allow space between the adjuster and the limit switch, next suspend a load, and then adjust the height of the adjuster.
- Changing the distance by 0.5mm (equivalent to a half turn of the adjuster) between the limit switch and adjuster makes a 15 % variation of the set load.

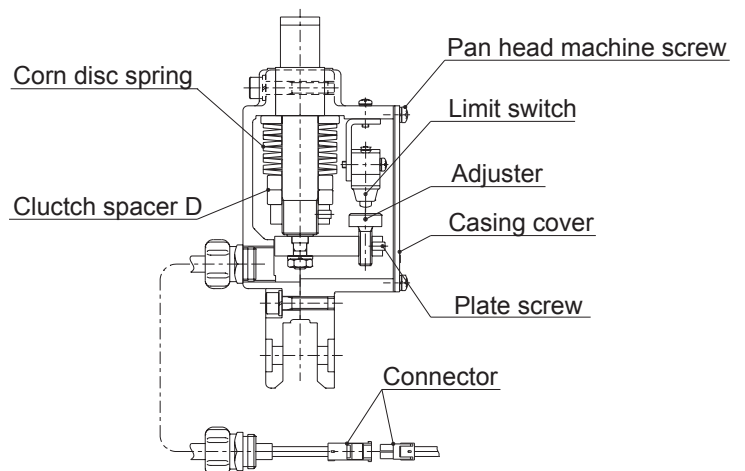

Overload Test

To carry out the overload test in accordance with local rules and regulations, deactivate the overload limiter as shown below:

For the disassembly and assembly procedures, refer and comply with all the instructions in “ER2 Series Electric Chain Hoist Disassembly and Assembly Manual” (separate document) (contact with your nearest dealer or KITO.)

■ How to conduct overload test

Deactivate the overload limiter before conducting the overload test as follows:

- 1) Remove the controller cover of the electric chain hoist by un-tightening the socket bolts.

- 2) Disconnect the connector on the OLL cable end.
 - Disconnection of the connector deactivates the overload limiter.

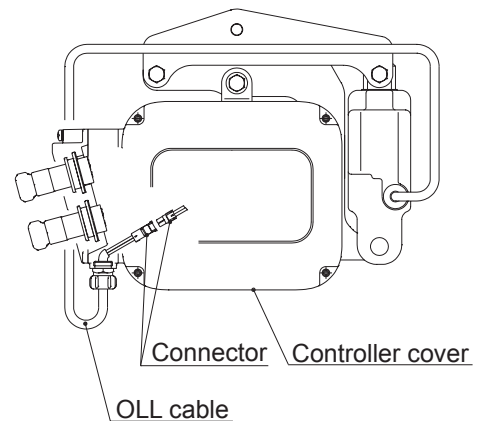

⚠ DANGER



Prohibited

- **Do not leave the connector disconnected after the overload test.**

Failure to follow these precautions may cause accidents resulting in serious or even fatal injury.

Maintenance

Conduct daily inspections and periodic inspections, based on the following checklist:

Overload Limiter Checklist

Item	Inspection period		Method	Criteria	Remedy
	Daily	Periodic			
Appearance	✓	✓	Visual check	No damage, deformation or remarkable corrosion.	Replace damaged parts.
Bolts and nuts		✓	Visual check	No loose bolts or nuts.	Fasten securely.
Suspender		✓	Make measurements with a vernier caliper.	The diameter of each hole wears 5% or less.	Replace damaged parts.
Bolts		✓	Make measurements with a vernier caliper.	The outer shape wears 5% or less.	Replace damaged parts.

< Memo >

A series of horizontal dotted lines for writing, spanning the width of the page.

KITO

URL. <http://www.kito.co.jp>