

# V10™ CLEVIS SHORTENING GRAB HOOK WITH RETAINER

For chain tightening, tie downs, or lifting applications, the V10™ Grab Hook with Retainer is your ideal choice. The safety retainer is designed to lock the chain in place and prevent it from slipping off the hook. With the entire chain link supported by the chain cradle, 100% of its Working Load Limit is maintained. The V10™ Grab Hook with Retainer is engineered to meet or exceed OSHA, Government, NACM, and ASTM standards. All V10™ products are accompanied with a product test certificate.



# V10™ CLEVIS SHORTENING GRAB HOOK WITH RETAINER

---

## GRADE

- 100

## FINISH

- Blue Powder Coat Finish

## STANDARDS

- Safety factor 4:1
- Meets or exceeds ASTM A952 & OSHA 910 Standards
- Fatigue Tested at 1.5 times the WLL for 20,000 cycles
- Proof Tested at twice the WLL

## ATTACHMENT

- Clevis

## HEAT TREATMENT

- Quenched and tempered before proof testing

## ORIGIN

- Made in Italy

## HOOK TYPE

- Grab Hook
- Chain cradle for optimal chain position and weight distribution
- Safety retainer to prevent chain slips

## APPLICATION

- Overhead Lifting
- For chain tightening, tie downs, or lifting applications

## MATERIAL

- Premium Fine Grain Alloy Steel

# V10™ CLEVIS SHORTENING GRAB HOOK WITH RETAINER

## DIAGRAM DRAWINGS

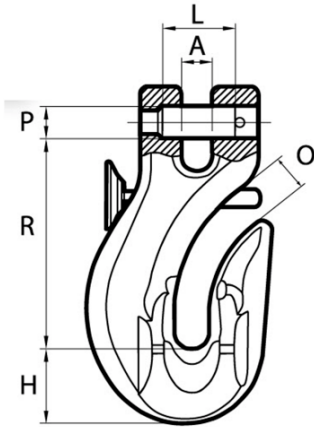

# V10™ CLEVIS SHORTENING GRAB HOOK WITH RETAINER

## PRODUCTS SPECIFICATIONS

Product	Manufacturer Part No.	Chain Size Inches	Chain Size mm	Dim A (in.)	Dim H (in.)	Dim O (in.)	Dim P x L (in.)	Dim R (in.)	Lbs. Per Ea.	Working Load Limit (Lbs.)
8429100		7/32	6	0.276	0.689	0.276	0.29 x 0.65	2.008	0.55	2,700
8429200	- - -	9/32 - 5/16	7 - 8	0.354	0.925	0.374	0.38 X 0.91	2.598	1.32	5700
8429400	- - -	3/8	10	0.453	1.142	0.472	0.49 X 1.16	3.228	2.51	8800
8429620	- - -	1/2	13	0.571	1.535	0.65	0.63 X 1.46	4.17	4.63	15000
8429720	- - -	5/8	16	0.709	1.811	0.866	0.79 X 2.05	5.118	8.38	22600